

# Sumitomo Drive Technologies

**Sumitomo Machinery Corporation of America**  
**Headquarters & Manufacturing**  
 4200 Holland Boulevard, Chesapeake, VA 23323



**Sumitomo Machinery Corp. of America**  
 Chesapeake, VA  
 Corona, CA  
 Glendale Heights, IL  
 Lufkin, TX  
 Verona, VA

Phone:	Fax:
+1.757.485.3355	+1.757.485.7490
+1.951.340.4100	+1.951.340.4108
+1.630.752.0200	+1.630.752.0208
+1.502.969.0378	+1.502.969.0380
+1.540.213.2442	+1.540.213.2222

**SM Cyclo de Mexico, S.A. de C.V.**  
 Monterrey  
 Guadalajara  
 Ciudad de México

+52.81.8144.5130	+52.81.8144.5130 ext. 3109
+52.33.3675.4323	+52.33.3675.4418
+52.55.2282.8700	+52.55.2282.8700

**SM Cyclo of Canada, Ltd.**  
 Toronto, ON  
 Vancouver, BC

+1.905.469.1050	+1.905.469.1055
+1.604.525.5403	+1.604.525.0879

**SM Cyclo Colombia, S.A.S.**  
 Bogotá

+57.1.300.0673	+57.1.300.0673 ext. 105
----------------	-------------------------

**Sumitomo Indústrias Pesadas do Brasil Ltda.**  
 São Paulo

+55.11.4403.9292	+55.11.4403.9292
------------------	------------------

**SM Cyclo de Chile Ltda.**  
 Santiago  
 Antofagasta  
 Concepción

+56.2.2892.7000	+56.2.2892.7001
+56.5.5256.1611	+56.5.5256.1616
+56.41.246.9806	+56.41.246.9171

**SM Cyclo de Guatemala Ensambladora, Ltda.**  
 Guatemala

+502.6648.0500	+502.6648.9171
----------------	----------------

**SM Cyclo de Argentina, SA**  
 Buenos Aires

+54.3327.45.4095	+54.3327.45.4099
------------------	------------------

## World Headquarters

Japan  
 Sumitomo Heavy Industries, Ltd.  
 Power Transmission & Controls Group  
 ThinkPark Tower, 1-1, Osaki 2-chome,  
 Shinagawa-ku, Tokyo 141-6025 Japan  
 Tel: +81-367-37-2511 • Fax: +81-368-66-5160

[www.sumitomodrive.com](http://www.sumitomodrive.com)

Catalog 17.086.50.002

# Sumitomo Drive Technologies

Sumitomo Drive Technologies

Advanced Gearboxes



## Advanced Gearboxes

Gearboxes for Servo Motors

## Table of Contents

**How To Select** ..... 1.2

### 1. Servo Cyclo®

General Information ..... 1.4

How To Configure ..... 1.9

Rating Tables ..... 1.12

Dimensions ..... 1.16

Technical Information ..... 1.21

### 2. Servo Bevel Buddybox

General Information ..... 2.1

How To Configure ..... 2.6

Rating Tables ..... 2.9

Dimensions ..... 2.33

Options ..... 2.36

Technical Information ..... 2.52

### 3. Servo Hyponic

General Information ..... 3.1

How To Configure ..... 3.6

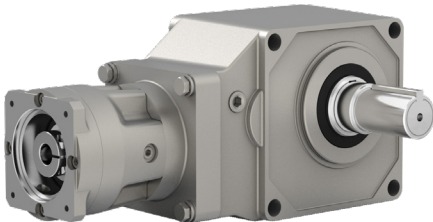
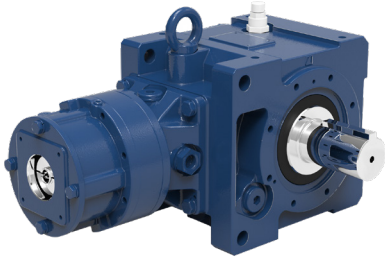
Rating Tables ..... 3.9

Dimensions ..... 3.13

Options ..... 3.18

Technical Information ..... 3.30

**Motor Codes** ..... i



# How to Select

## 1. Flowchart and Formula for Selection

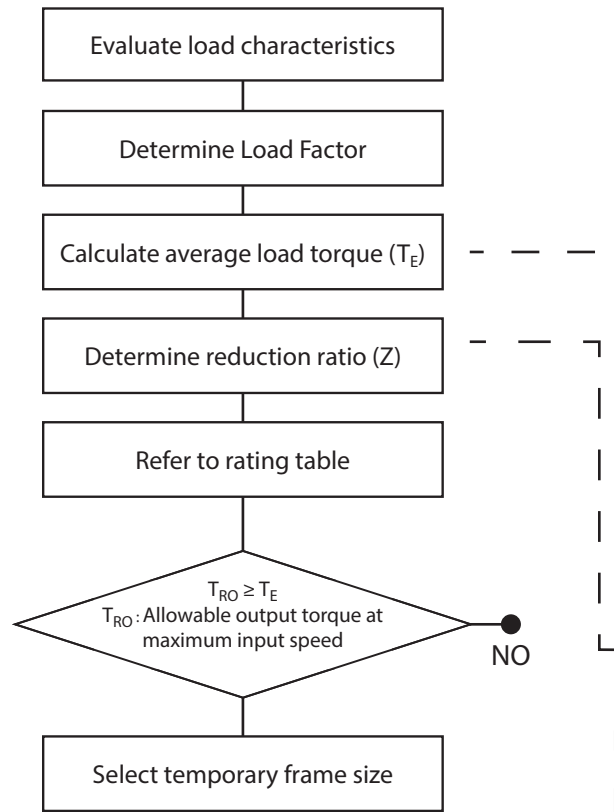
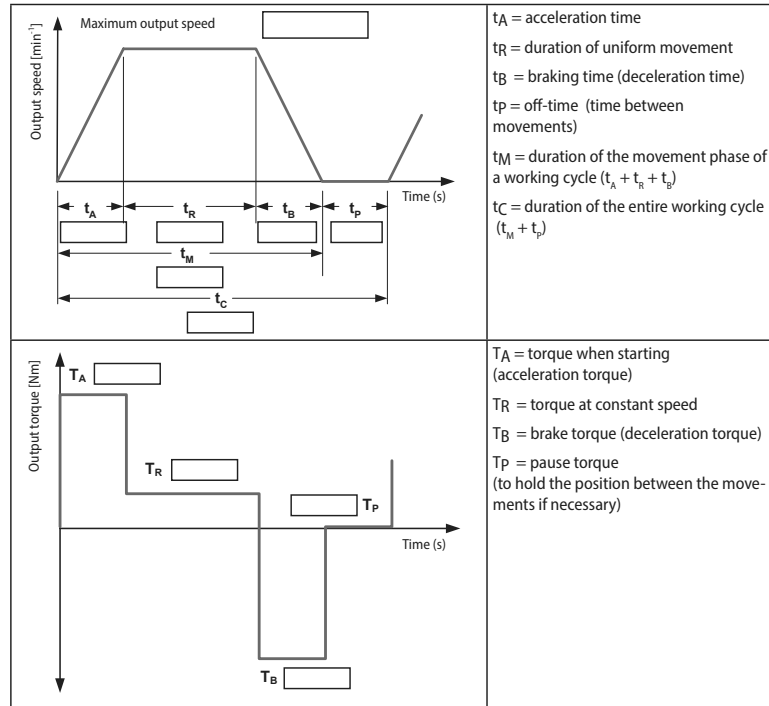


Table 1.1  $F_n$  Startup frequency factor

Startup Frequency	Factor
1~2 times/min	1.0
3~5 times/min	1.1
6~9 times/min	1.2

Table 1.2  $F_{SF}$  Load Factor

Operation Time	Load Condition		
	U (Uniform shock)	M (Light shock)	H (Heavy shock)
~10 hours/day	1.0	1.0	1.4
24 hours/day	1.2	1.35	1.6

Table 1.3 Load Characteristics Table for Machinery

Transportation & Distribution Machines	Metal Processing Machine	Printing Machine
Conveyor (uniform load) Apron, Assembly, Belt, Bucket, Chain, Oven, Screw	Tapping Machine Punch Press (gear operation) Planer Bending Machine ATC General Machine Tools	Textile, Spinning and Weaving Batcher, Calendar, Card, Driving Can, Dryer, Dyeing Machine, Mangle, Napper, Pad, Slasher, Soaper, Winder, Spinning Machine, Stenter, Fabric Washing Machine, Fabric Finishing Machine (Fabric Washing Machine, Pad, Stenter, Dryer, Calendar, etc.)
Conveyor (heavy load, intermittent) Apron, Assembly, Belt, Bucket Sorting apparatus AGV		
Peripheral equipment for robots Slider Positioner		

● Average load torque  $T_E = \left( \frac{\frac{1}{2} \cdot T_A^{10/3} \cdot t_A + T_R^{10/3} \cdot t_R + \frac{1}{2} \cdot T_B^{10/3} \cdot t_B}{\frac{1}{2} \cdot t_A + t_R + \frac{1}{2} \cdot t_B} \right)^{0.3}$

● Reduction ratio  $Z = \left( \frac{\text{Output Speed}}{\text{Maximum input speed}} \right)$

● %ED  $\%ED = \frac{t_o}{T} \times 100$

Maximum operation cycle is 10 minutes when calculation % ED. Assign T - 10 (min) when calculating for cycle over this time.

## 2. Selection Example

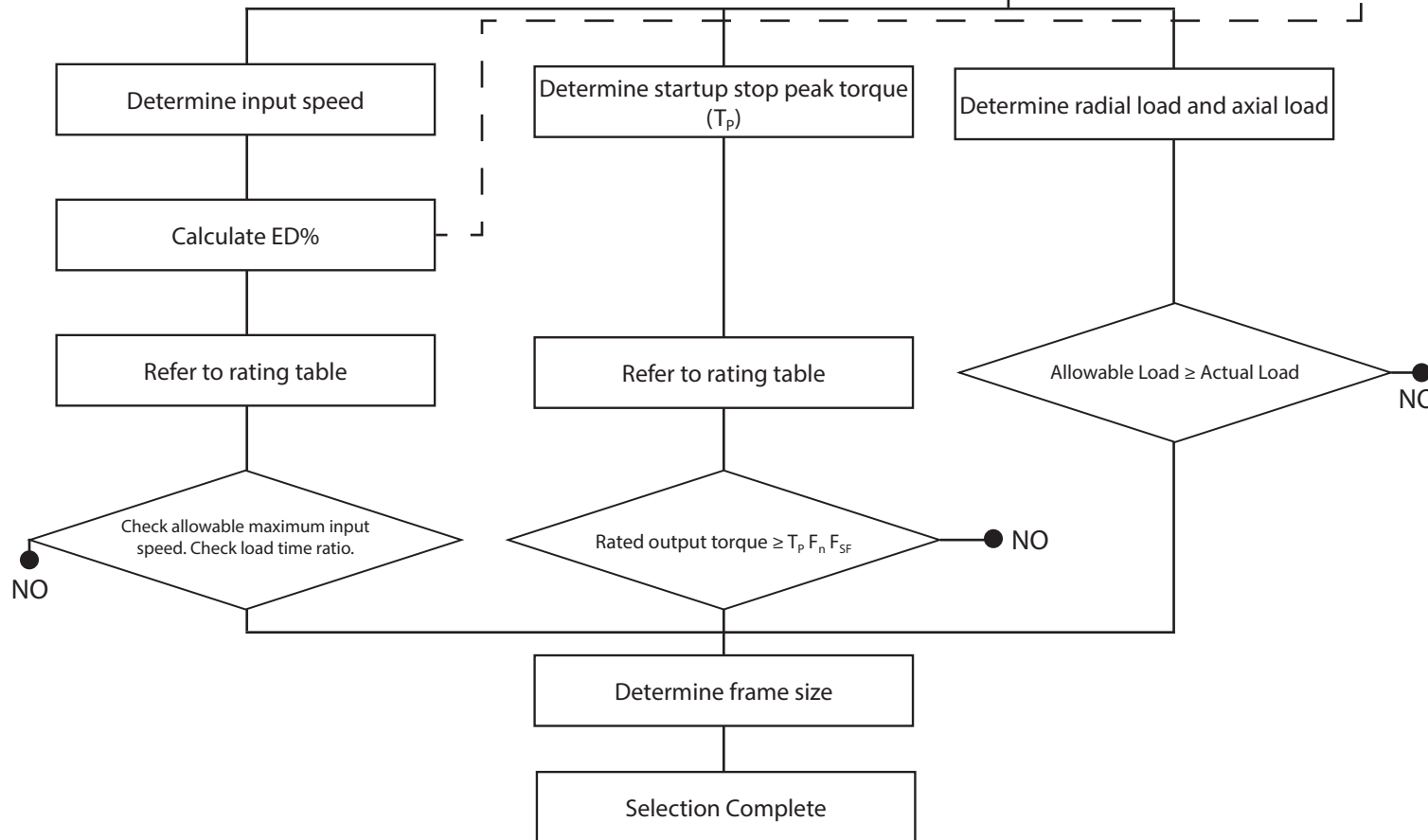
<Applications> Low backlash specification for transportation vehicle drive

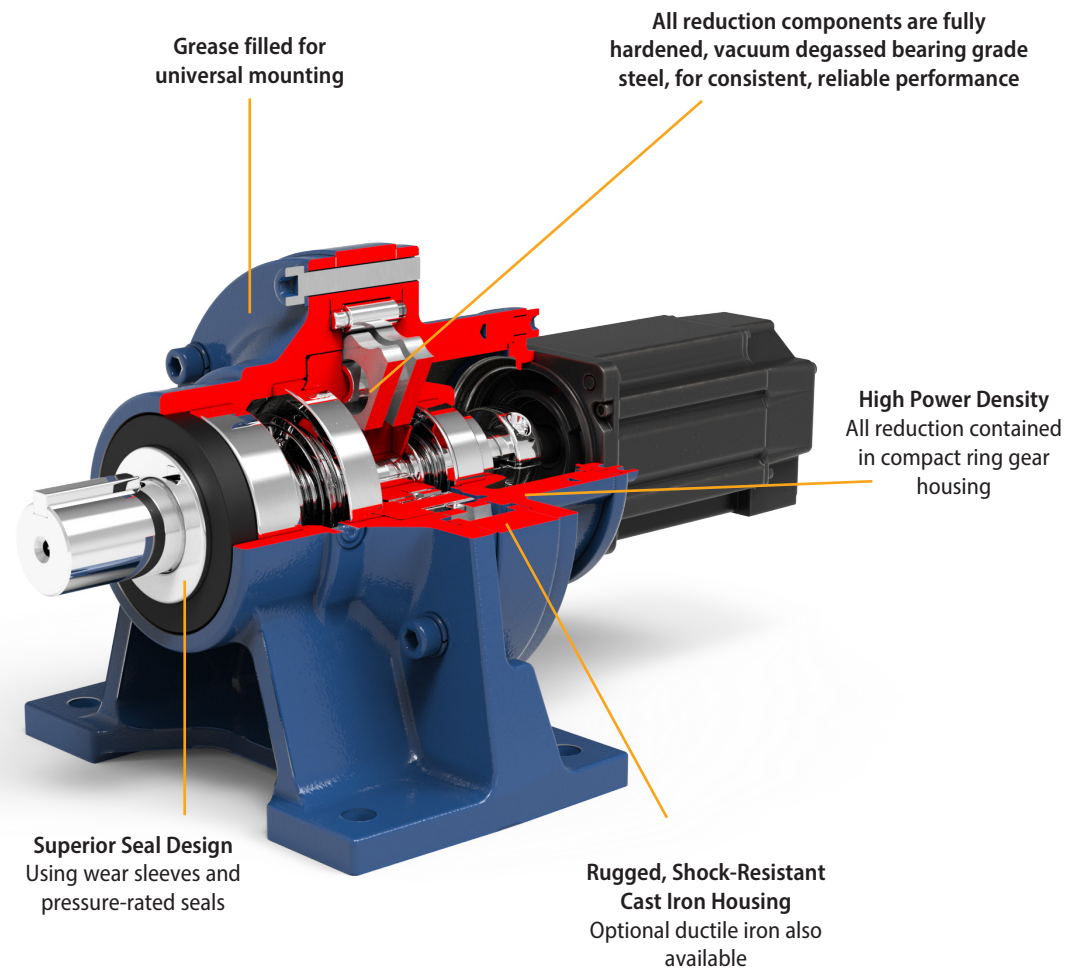
<Specification>

$T_A$ : Acceleration peak torque	8.0 kgf·m	$n$ : Maximum output speed	69 r/min
$T_R$ : Torque during normal running	0.7 kgf·m	$t_A$ : Acceleration time	0.5 sec
$T_B$ : Peak torque at braking	4.9 kgf·m	$t_R$ : Normal running time	6.5 sec
		$t_B$ : Deceleration time	1.0 sec
		$t_M$ : Total running time	8.0 sec
		$t_p$ : Standstill time	8.0 sec
		$t_C$ : Time/Cycle	16.0 sec

Radial Load 200 kgf is applied to the midpoint of slow speed shaft.  
Rated speed of servo motor is 2000 r/min  
10 hours/day operation

- Determine Load Factor  $F_n = 1.1$ ,  $F_{SD} = 1.0$
  - Calculate  $T_E = \left( \frac{\frac{1}{2} \cdot 8.0^{10/3} \cdot 0.5 + 0.7^{10/3} \cdot 6.5 + \frac{1}{2} \cdot 4.9^{10/3} \cdot 1}{\frac{1}{2} \cdot 0.5 + 6.5 + \frac{1}{2} \cdot 1.0} \right)^{0.3} = 3.2 \text{ (kgf·m)}$
  - Determine reduction ratio  $Z = \left( \frac{69}{2000} \right) = \frac{1}{29}$
  - Calculate allowable output torque at maximum input speed  $T_{RO} = 13.2 \text{ (kgf·m)} > 3.2 \text{ (kgf·m)}$  » Select temporary frame size 6095 #29
  - Calculate ED%  $\%ED = \frac{8}{16} \times 100 = 50\%$
  - Check maximum input speed 2000 (r/min) at 50% ED < 4000 (r/min) at 50% ED
  - Check peak torque at startup stop  $8.0 \text{ (kgf·m)} \times 1.1 \times 1.0 = 8.8 \text{ (kgf·m)} < 20.4 \text{ (kgf·m)}$
  - Allowable radial load of slow speed shaft with factor in consideration  $Pro = 339 \text{ (kgf)}$ ,  $Lf = 1.0$ ,  $Cf = 1.25$ ,  $Fs = 1.2$
- $\frac{Pro}{Lf \times Cf \times Fs} = \frac{339}{1.0 \times 1.25 \times 1.2} = 226 \text{ (kgf)} > 200 \text{ (kgf)}$
- Frame size 6095 #29 from the calculation above





### Product Description

Sumitomo Cyclo® speed reducers are the **premier in-line gearboxes**. The revolutionary Cyclo® design provides **quiet, efficient, and reliable performance** exceeding that of involute tooth gear designs. The key to Cyclo®'s matchless performance and reliability is that 67% of the reduction components are in contact at all times, compared to geared designs that use only limited tooth contact. Unlike geared designs, the Cyclo®'s reduction components operate in compression rather than shear, which results in **exceptionally rugged and shock resistant performance**. The Cyclo® technology coupled with innovative product options and accessories offers the most extensive range of application solutions available.

### Features & Benefits

- **Universal mounting arrangements**
  - ~ Standard clamp ring input
  - ~ Available keyed hollow bore option
- **Internal components manufactured from hardened, vacuum-degassed, bearing grade steel**
  - ~ Minimal vibration, low noise, low backlash and extended operational life
- **The best product warranty**
  - ~ The 24 month warranty backs up the superb Cyclo® product reputation
- **Up to 95% efficiency**

### General Specifications Summary

<b>Sizes:</b>	8 sizes
<b>Torque Rating:</b>	7.5 Nm - 1370 Nm
<b>Power Rating:</b>	0.347 kW - 15.1 kW
<b>Ratio Range:</b>	6:1 to 87:1
<b>Mounting:</b>	Foot, Flange, Face Mount

- ▶ **Sumitomo's Servo Cyclo® is a highly reliable, torque dense cycloidal speed reducer**



- Simple, Compact Design
- Rugged Forged Output Shaft
- Universal Mounting

For additional CYCLO® 6000 information, please visit [www.sumitomodrive.com](http://www.sumitomodrive.com)

## Unmatched Reliability, Exceptional Performance

- ▶ **The Servo Cyclo® is designed to withstand shock-loads exceeding 500% of their ratings**



### ▶ Applications

- Conveyors
- Food Machinery
- Mixers
- Automotive Plants
- Recycling Machines
- Poultry Plants
- Sawmills and Wood Mills
- Wastewater Treatment
- Steel Mills
- Construction Equipment
- Paper Mills
- Processing Plants

# FAQs

### How do I select a Servo Cyclo® gearbox?

Selection is based on the motor speed and torque requirements at the output shaft. The Servo Cyclo® gearbox has particularly high efficiencies over a wide range of reduction ratios, which frequently permits the use of reduced input power requirements (smaller kW motor) without sacrificing output shaft torque. The selection procedures in this catalog will guide you in choosing the most efficient gearbox for your application.

### What information do I need to get started in the selection process?

To select the proper gearbox for your application, you will need to know:

1. Speed and torque requirements of application
2. Hours of operation per day
3. Moment loads
4. Type of load factor

If there are any special environmental factors or operation requirements, they must also be noted. This information will be important in determining the Service Factor of your application.

### What are Service Classes and how are they used?

In general, gearboxes are rated for the specific conditions and operating requirements of the application by the use of AGMA-defined Service Classes. There are three AGMA Service Classifications for gearmotors: uniform (U), moderate shock (M) and heavy shock (H). The Service Classes are used in the product selection process to adjust for the specific conditions and operating requirements of your application.

### What do I do if my application has particularly severe operating conditions?

The standard ratings for Servo Cyclo® are based on 10-hour daily service under conditions of uniform loads. By following the product selection process, you will determine and apply the Service Factors to compensate for longer periods of operation and/or severe operating conditions.

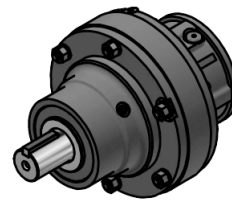
### How can I be sure that the reducer can withstand periodic excessive overloads?

Servo Cyclo® gearboxes provide 500% momentary intermittent shock load capacity. For applications with shock loads greater than 500%, consult an SMA Application Engineer.

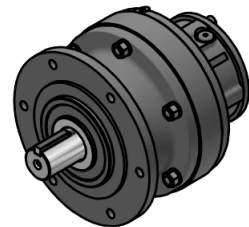
### What thermal capacity limitations does the Cyclo® have?

The Servo Cyclo® gearbox, by virtue of its smooth, almost frictionless operation (unlike traditional helical gears), has a thermal rating that far exceeds its mechanical capacity and all but eliminates the conventional limitations due to heat under normal ambient conditions.

### Additional Configurations



Single Reduction, Flange Mount with Servo Motor Adapter



Single Reduction, V-Flange Mount with Servo Motor Adapter

# Standard Specifications

<b>Reducer</b>	<b>Reduction:</b>	Trochoidal curved tooth profile gear mechanics
	<b>Lubrication:</b>	Grease lubricated models available
	<b>Seals:</b>	Nitrile material, dual lipped, double output seals available
	<b>Material:</b>	Rugged cast iron or ductile housings
	<b>Paint Color:</b>	Blue, Munsell color number 6.5PB 3.6/8.2

<b>Ambient Conditions</b>	<b>Installation Location:</b>	Indoors (Minimal dust and humidity)
	<b>Ambient Temperature:</b>	14° ~104° F (-10° ~ 40° C)
	<b>Ambient Humidity:</b>	Under 85%
	<b>Elevation:</b>	Under 1,000 meters (Under 3,281 ft.)
	<b>Atmosphere:</b>	Well ventilated location, free of corrosive gases, explosive, vapors, and dust

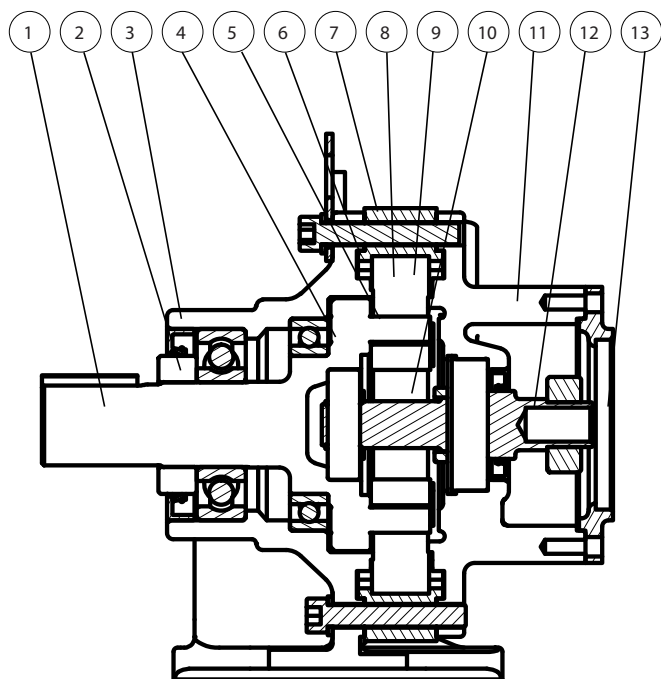
### Shaft Rotation

On single reduction Servo Cyclo® gearboxes, ratios 6 through 87, the slow speed shaft rotates in a reverse direction to that of the high speed shaft.

### Thermal Capacity

The Servo Cyclo® gearbox's smooth, almost frictionless operation all but eliminates the conventional limitations due to heat. In all sizes, Servo Cyclo® gearboxes have thermal ratings that exceed their mechanical capacity.

# Structure



No.	Part Name
1	Slow Speed Shaft
2	Collar
3	Horizontal Casing
4	Slow Speed Shaft Pin
5	Slow Speed Shaft Roller
6	Ring Gear Pin
7	Ring Gear Housing
8	Spacer Ring
9	Cycloid Disc
10	Eccentric Cam
11	High Speed Shaft End Shield
12	High Speed Shaft
13	Motor Plate

## Standard Series

Frame Size	6060, 6065						6070, 6075						6080, 6085						6090, 6095										
Reduction Ratio	6	11	15	21	29	43	6	11	15	21	29	43	59	6	11	15	21	29	43	59	87	6	11	15	21	29	43	59	87
Backlash	Consult us for each case. Backlash varies depending on the frame size reduction ratio.																												
Max. Allowable Input Speed	4000 r/min (10 min cycle, 50% ED)																												

Frame Size	6100, 6105								6110, 6115								6120, 6125							
Reduction Ratio	6	11	15	21	29	43	59	87	6	11	15	21	29	43	59	87	6	11	15	21	29	43	59	87
Backlash	Consult us for each case. Backlash varies depending on the frame size reduction ratio.																							
Max. Allowable Input Speed	4000 r/min (10 min cycle, 50% ED)																							

# 2

# How to Configure

---

# Configure a Model Number

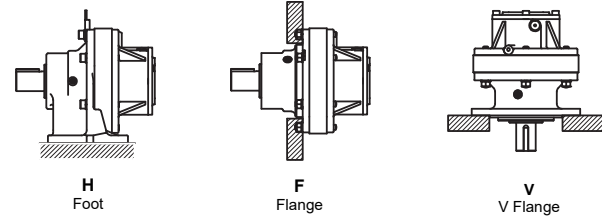
# Nomenclature

### Output Shaft Orientation

Type	Prefix
Horizontal	H
Vertical	V
Vertical Up (Solid Shaft)	W
Universal Direction	N

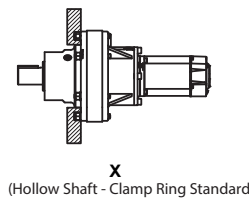
### Housing Style

Type	Prefix
Foot	H
Flange	F
V-Flange	V



### Input Connection

Motor Connection	Prefix
Hollow Input Shaft	X



### Modification (Special)

	Prefix
Special	S
Standard	-

### Shaft Specification

Input Shaft	Suffix
Inch	Y
Metric DIN	G
Metric JIS	-

### Frame Size (from Ratings Tables)

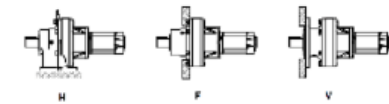
### Reducer Specification

Input Shaft	Suffix
High Capacity	R1
High Capacity Bearing	R2
Ductile Casing	
Baseplate	BP
Shovel Base	SB

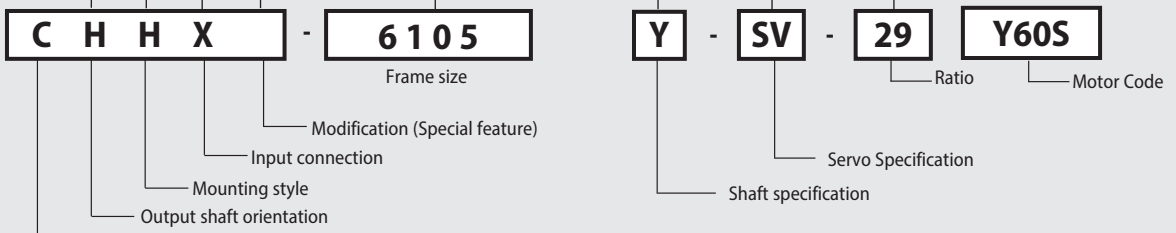
### Nominal Ratio

Servo Cyclo®

## Rating Tables



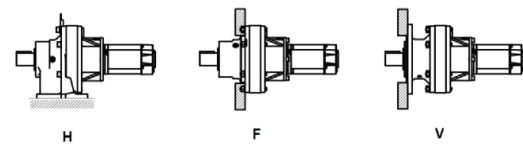
Size	Ratio	Input Speed												Allowable Max Input Speed r/min	Allowable Peak Torque at Startup and Stop N-m
		4000 r/min				3000 r/min				2000 r/min					
		Allowable Input Power kW	Rated Output Torque N-m	Allowable Radial Load N	Max %ED	Allowable Input Power kW	Rated Output Torque N-m	Allowable Radial Load N	Max %ED	Allowable Input Power kW	Rated Output Torque N-m	Allowable Radial Load N	Max %ED		
6070	6	0.554	7.5	980		0.554	10.1	1080		0.347	9.43	1240		4000	29.7
	11	0.554	13.8	1200		0.554	18.5	1330		0.347	17.3	1530		4000	45.0
	15	0.554	18.8	1270		0.554	25.2	1400		0.347	23.6	1620		4000	45.0
	17	0.554	21.3	1340		0.554	28.5	1480		0.347	26.8	1710		4000	45.0
	21	0.511	24.3	1350	30	0.511	32.5	1490	50	0.320	30.5	1730	100	4000	45.0
	29	0.257	16.9	1380		0.257	22.6	1520		0.226	29.7	1720		4000	45.0
6070	43	0.243	23.6	1370		0.243	31.6	1510		0.170	33.1	1740		4000	45.0
	59	0.119	15.9	1440		0.119	21.3	1590		0.100	26.8	1770		4000	45.0



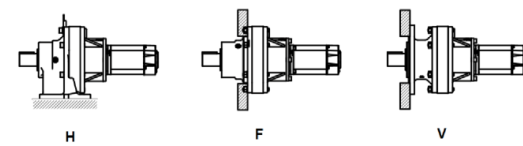
C = Ratios 6:1 and greater (Cyclo Gearmotor product code)  
P = Ratios 3:1 and 5:1 (Cyclo 6000 planetary product code)



# Rating Tables



# Rating Tables



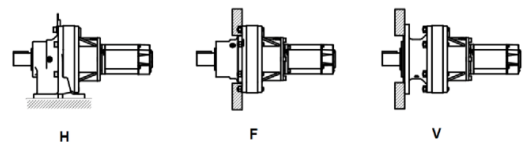
Size	Ratio	Input Speed												Allowable Max Input Speed r/min	Allowable Peak Torque at Startup and Stop N·m
		4000 r/min				3000 r/min				2000 r/min					
		Allowable Input Power kW	Rated Output Torque N·m	Allowable Radial Load N	Max %ED	Allowable Input Power kW	Rated Output Torque N·m	Allowable Radial Load N	Max %ED	Allowable Input Power kW	Rated Output Torque N·m	Allowable Radial Load N	Max %ED		
6070	6	0.554	7.5	980	30	0.554	10.1	1080	50	0.347	9.43	1240	100	4000	29.7
	11	0.554	13.8	1200		0.554	18.5	1330		0.347	17.3	1530		4000	45.0
	15	0.554	18.8	1270		0.554	25.2	1400		0.347	23.6	1620		4000	45.0
	17	0.554	21.3	1340		0.554	28.5	1480		0.347	26.8	1710		4000	45.0
	21	0.511	24.3	1350		0.511	32.5	1490		0.320	30.5	1730		4000	45.0
	29	0.257	16.9	1380		0.257	22.6	1520		0.226	29.7	1720		4000	45.0
	43	0.243	23.6	1370		0.243	31.6	1510		0.170	33.1	1740		4000	45.0
	59	0.119	15.9	1440		0.119	21.3	1590		0.100	26.8	1770		4000	45.0
	87	-	-	-		-	-	-		-	-	-		-	-
6075	6	0.650	8.8	980	30	0.650	11.8	1080	50	0.407	11.1	1240	100	4000	29.7
	11	0.650	16.2	1190		0.650	21.7	1320		0.407	20.3	1520		4000	50.8
	15	0.650	22.1	1260		0.650	29.5	1390		0.407	27.7	1610		4000	60.0
	17	0.650	25.0	1320		0.650	33.5	1460		0.407	31.4	1700		4000	60.0
	21	0.650	30.9	1320		0.650	41.3	1460		0.407	38.8	1700		4000	60.0
	29	0.325	21.3	1360		0.325	28.5	1500		0.286	37.6	1700		4000	60.0
	43	0.325	31.6	1340		0.325	42.3	1480		0.226	44.1	1710		4000	60.0
	59	0.162	21.6	1420		0.162	28.9	1570		0.136	36.3	1770		4000	60.0
	87	-	-	-		-	-	-		-	-	-		-	-
6090	6	1.26	17.1	2020	30	1.26	22.9	2230	50	1.15	31.2	2540	100	4000	142
	11	1.21	30.1	2560		1.21	40.3	2820		1.15	57.2	3210		4000	150
	15	1.15	39.1	2570		1.15	52.2	2830		1.15	78.0	3210		4000	150
	17	1.15	44.3	2580		1.15	59.2	2850		1.15	88.7	3220		4000	150
	21	0.758	36.1	2610		0.758	48.2	2880		0.758	72.2	3270		4000	150
	29	0.673	44.2	2780		0.673	59.1	3060		0.625	82.3	3340		4000	150
	43	0.469	45.7	3030		0.469	61.1	3340		0.435	84.9	3340		4000	150
	59	0.392	52.4	3030		0.392	70.1	3340		0.309	82.7	3340		4000	146
	87	0.261	51.5	3030		0.261	68.8	3340		0.211	83.3	3340		4000	150
6095	6	1.66	22.5	2000	30	1.66	30.2	2210	50	1.52	41.2	2520	100	4000	170
	11	1.60	39.9	2540		1.60	53.3	2800		1.52	75.6	3170		4000	200
	15	1.52	51.7	2540		1.52	69.1	2800		1.52	103	3160		4000	200
	17	1.52	58.6	2560		1.52	78.3	2820		1.52	117	3170		4000	200
	21	1.51	71.9	2540		1.51	96.0	2800		1.52	144	3140		4000	200
	29	0.844	55.5	2760		0.844	74.1	3040		0.784	103	3340		4000	200
	43	0.650	63.3	3030		0.650	84.7	3340		0.603	118	3340		4000	200
	59	0.426	57.0	3030		0.426	76.1	3340		0.384	103	3340		4000	146
	87	0.325	64.1	3030		0.325	85.6	3340		0.301	119	3340		4000	195

1. Allowable input power is based on rated output torque with gearbox efficiency consideration.  
 2. Rated torque is the allowable value of the average load torque at the output shaft. The rated torque for the input speed of 1000 r/min or less is the same as the rated torque of 1000 r/min.  
 3. Radial load value is based on overhang load applied at centre of output shaft.

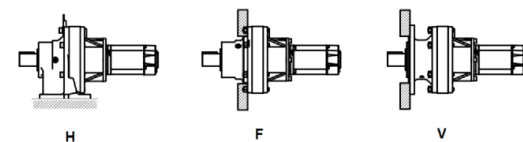
Size	Ratio	Input Speed								Allowable Max Input Speed r/min	Allowable Peak Torque at Startup and Stop N·m
		1500 r/min				1000 r/min					
		Allowable Input Power kW	Rated Output Torque N·m	Allowable Radial Load N	Max %ED	Allowable Input Power kW	Rated Output Torque N·m	Allowable Radial Load N	Max %ED		
6070	6	0.347	12.6	1360	100	0.347	18.9	1540	100	4000	29.7
	11	0.347	23.1	1680		0.347	34.6	1770		4000	45.0
	15	0.347	31.4	1770		0.331	45.0	1770		4000	45.0
	17	0.347	35.7	1770		0.292	45.0	1770		4000	45.0
	21	0.320	40.7	1770		0.236	45.0	1770		4000	45.0
	29	0.226	39.6	1770		0.171	45.0	1770		4000	45.0
	43	0.170	44.1	1770		0.115	45.0	1770		4000	45.0
	59	0.100	35.7	1770		0.084	45.0	1770		4000	45.0
	87	-	-	-		-	-	-		-	-
6075	6	0.407	14.8	1350	100	0.407	22.1	1530	100	4000	29.7
	11	0.407	27.1	1660		0.407	40.6	1770		4000	50.8
	15	0.407	36.9	1750		0.407	55.4	1770		4000	60.0
	17	0.407	41.8	1770		0.389	60.0	1770		4000	60.0
	21	0.407	51.7	1770		0.315	60.0	1770		4000	60.0
	29	0.286	50.2	1770		0.228	60.0	1770		4000	60.0
	43	0.226	58.8	1690		0.154	60.0	1660		4000	60.0
	59	0.136	48.4	1720		0.102	54.6	1630		4000	60.0
	87	-	-	-		-	-	-		-	-
6090	6	1.15	41.6	2780	100	1.15	62.4	3160	100	4000	142
	11	1.15	76.3	3340		1.15	114	3340		4000	150
	15	1.15	104	3340		1.10	150	3340		4000	150
	17	1.15	118	3340		0.972	150	3340		4000	150
	21	0.758	96.2	3340		0.758	144	3340		4000	150
	29	0.625	110	3340		0.570	150	3290		4000	150
	43	0.435	113	3340		0.384	150	3310		4000	150
	59	0.309	110	3340		0.273	146	3300		4000	146
	87	0.211	111	3340		0.190	150	3310		4000	150
6095	6	1.52	55.0	2760	100	1.52	82.5	3110	100	4000	170
	11	1.52	101	3340		1.52	151	3340		4000	200
	15	1.52	137	3340		1.47	200	3340		4000	200
	17	1.52	156	3340		1.30	200	3340		4000	200
	21	1.52	192	3340		1.05	200	3340		4000	200
	29	0.784	137	3320		0.709	187	3220		4000	200
	43	0.603	157	3300		0.478	187	3240		4000	200
	59	0.342	122	3340		0.273	146	3300		4000	146
	87	0.270	142	3330		0.198	156	3300		4000	195

4. Max %ED when 3000rpm and 4000rpm would be 50 %ED and 30 %ED respectively.  
 5. Allowable peak torque is the max mechanical rating of Cyclo during starting up and stopping the connected machine load.

# Rating Tables



# Rating Tables



Size	Ratio	Input Speed												Allowable Max Input Speed r/min	Allowable Peak Torque at Startup and Stop N·m
		4000 r/min				3000 r/min				2000 r/min					
		Allowable Input Power kW	Rated Output Torque N·m	Allowable Radial Load N	Max %ED	Allowable Input Power kW	Rated Output Torque N·m	Allowable Radial Load N	Max %ED	Allowable Input Power kW	Rated Output Torque N·m	Allowable Radial Load N	Max %ED		
6100	6	2.64	35.9	2930	30	2.64	48.0	3230	50	2.35	63.9	3690	100	4000	171
	11	2.64	65.8	3710		2.64	88.0	4090		2.35	117	4660		4000	250
	15	2.64	89.8	4070		2.64	120	4490		2.35	160	5110		4000	250
	17	2.23	85.9	4150		2.23	115	4570		1.99	153	5210		4000	250
	21	2.03	96.6	4170		2.03	129	4590		1.93	183	5210		4000	250
	29	1.23	80.9	4160		1.23	108	4580		1.21	159	5210		4000	250
	43	0.811	79.0	4150		0.811	106	4570		0.780	152	5210		4000	250
	59	0.603	80.6	4130		0.603	108	4550		0.516	138	5200		4000	250
	87	0.560	111	4500		0.560	148	4960		0.433	171	5400		4000	250
6105	6	3.57	48.5	2910	30	3.57	64.9	3210	50	3.18	86.5	3660	100	4000	171
	11	3.57	89.0	3670		3.57	119	4050		3.18	159	4610		4000	308
	15	3.57	121	4030		3.57	162	4440		3.18	216	5040		4000	300
	17	2.76	106	4120		2.76	142	4540		2.46	190	5170		4000	300
	21	2.44	116	4140		2.44	155	4560		2.34	223	5170		4000	300
	29	1.62	107	4130		1.62	142	4550		1.59	209	5170		4000	300
	43	1.22	119	4110		1.22	159	4530		1.08	211	5170		4000	300
	59	0.796	107	4110		0.796	142	4530		0.708	190	5160		4000	296
	87	0.650	128	4300		0.650	171	4740		0.565	223	5400		4000	300
6120	6	-	-	-	30	-	-	-	50	4.85	132	4670	100	2400	366
	11	5.07	126	4710		5.07	169	5190		5.07	253	5880		4000	525
	15	5.07	172	5210		5.07	230	5740		5.07	345	6500		4000	525
	17	5.07	195	5260		5.07	261	5790		5.07	391	6550		4000	520
	21	4.97	237	5760		4.97	316	6340		3.96	377	7250		4000	522
	29	3.12	205	6350		3.12	274	7000		2.99	394	7950		4000	520
	43	2.04	199	7220		2.04	266	7950		1.91	373	9050		4000	525
	59	1.46	195	7540		1.46	261	8300		1.30	348	9460		4000	525
	87	1.12	221	7620		1.12	295	8390		0.944	372	9580		4000	525
6125	6	-	-	-	30	-	-	-	50	4.85	132	4670	100	2400	366
	11	6.92	173	4660		6.92	231	5130		5.92	295	5840		4000	622
	15	6.45	219	5160		6.45	293	5680		5.92	403	6440		4000	630
	17	6.17	238	5210		6.17	318	5740		5.66	436	6510		4000	630
	21	6.01	286	5700		6.01	382	6280		4.88	465	7170		4000	630
	29	3.77	248	6310		3.77	331	6950		3.77	496	7860		4000	630
	43	2.50	244	7180		2.50	326	7910		2.38	464	8970		4000	630
	59	1.82	244	7490		1.82	325	8250		1.62	434	9390		4000	630
	87	1.22	241	7600		1.22	321	8370		1.13	446	9530		4000	630

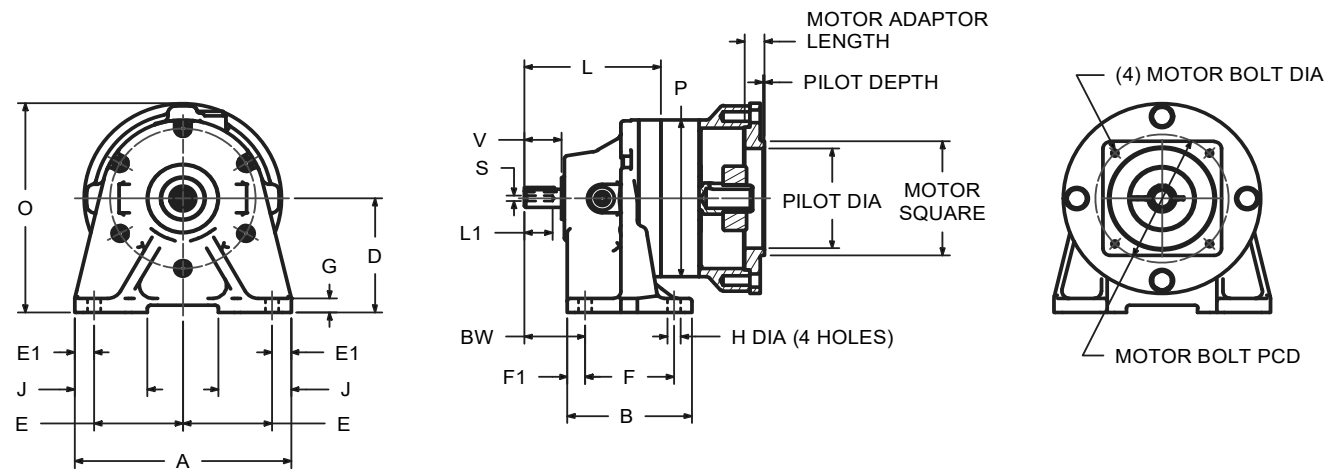
1. Allowable input power is based on rated output torque with gearbox efficiency consideration.  
 2. Rated torque is the allowable value of the average load torque at the output shaft. The rated torque for the input speed of 1000 r/min or less is the same as the rated torque of 1000 r/min.  
 3. Radial load value is based on overhang load applied at centre of output shaft.

Size	Ratio	Input Speed								Allowable Max Input Speed r/min	Allowable Peak Torque at Startup and Stop N·m
		1500 r/min				1000 r/min					
		Allowable Input Power kW	Rated Output Torque N·m	Allowable Radial Load N	Max %ED	Allowable Input Power kW	Rated Output Torque N·m	Allowable Radial Load N	Max %ED		
6100	6	2.35	85.2	4040	100	2.350	128	4590	100	4000	171
	11	2.35	156	5100		2.350	234	5400		4000	250
	15	2.35	213	5400		1.840	250	5400		4000	250
	17	1.99	205	5400		1.620	250	5400		4000	250
	21	1.93	245	5400		1.310	250	5400		4000	250
	29	1.21	212	5400		0.950	250	5400		4000	250
	43	0.780	203	5400		0.641	250	5400		4000	250
	59	0.516	184	5400		0.467	250	5400		4000	250
	87	0.433	228	5400		0.317	250	5400		4000	250
6105	6	3.18	115	4000	100	3.07	167	4540	100	4000	171
	11	3.18	212	5030		2.90	290	5400		4000	308
	15	3.18	288	5400		2.20	300	5400		4000	300
	17	2.46	253	5400		1.95	300	5400		4000	300
	21	2.34	297	5400		1.57	300	5400		4000	300
	29	1.59	279	5400		1.14	300	5400		4000	300
	43	1.08	281	5400		0.769	300	5400		4000	300
	59	0.694	248	5400		0.539	288	5290		4000	296
	87	0.516	272	5400		0.378	299	4830		4000	300
6120	6	5.07	184	5100	100	5.07	276	5770	100	2400	366
	11	5.07	337	6420		5.07	506	7220		4000	525
	15	5.07	460	7070		3.86	525	8100		4000	525
	17	5.05	519	7120		3.37	520	8220		4000	520
	21	3.96	503	7900		2.74	522	9090		4000	522
	29	2.96	519	8670		1.98	520	9810		4000	520
	43	1.91	497	9810		1.35	525	9810		4000	525
	59	1.30	464	9810		0.981	525	9810		4000	525
	87	0.944	497	9810		0.665	525	9780		4000	525
6125	6	6.96	253	5030	100	6.50	354	5690	100	2400	366
	11	5.92	394	6360		5.26	525	7200		4000	622
	15	5.92	537	7000		4.63	630	7990		4000	630
	17	5.66	582	7070		4.08	629	8120		4000	630
	21	4.88	620	7790		3.31	630	8990		4000	630
	29	3.59	630	8570		2.39	630	9810		4000	630
	43	2.38	619	9780		1.61	630	9810		4000	630
	59	1.62	578	9810		1.18	630	9810		4000	630
	87	1.05	553	9720		0.773	610	9600		4000	630

4. Max %ED when 3000rpm and 4000rpm would be 50 %ED and 30 %ED respectively.  
 5. Allowable peak torque is the max mechanical rating of Cyclo during starting up and stopping the connected machine load.

# Dimensions

## CNHX-6060/5 ▶ 6110/5



Dimensions are in inches

Model	A	B	L	D	E	E1	F	F1	G	H	J	O	P	BW
6060Y	5.67	3.31	3.62	3.150	2.36	0.47	2.36	0.47	0.39	0.35	1.38	5.77	4.33	1.61
6070/5	5.67	3.31	3.86	3.150	2.36	0.47	2.36	0.47	0.39	0.35	1.38	5.31	4.33	1.85
6080/5	5.67	3.90	5.08	3.543	2.36	0.47	2.95	0.47	0.51	0.35	1.46	6.18	5.28	2.05
6090/5	7.09	5.31	5.59	3.937	2.95	0.59	3.54	0.59	0.47	0.43	1.57	6.89	5.91	2.36
6100/5	7.09	5.31	6.14	3.937	2.95	0.59	3.54	0.59	0.47	0.43	1.57	8.15	5.91	2.36
6110/5	7.09	5.31	6.69	4.724	2.95	0.59	3.54	0.54	0.47	0.43	1.77	9.29	6.38	2.76

Model	Low Speed Shaft				
	U*	V	S	L1	Key
6060/5	0.500	0.98	10-32UNF	0.63	1/8 X 1/8 X .79
6070/5	0.750	1.18	12-28UNF	0.63	3/16 X 3/16 X 1.06
6080/5	0.875	1.38	12-28UNF	0.63	3/16 X 3/16 X 1.18
6090/5	1.125	1.38	5/16-18UNC	0.79	1/4 X 1/4 X 1.18
6100/5	1.125	1.38	5/16-18UNC	0.79	1/4 X 1/4 X 1.18
6110/5	1.250	1.77	5/16-18UNC	0.79	1/4 X 1/4 X 1.46

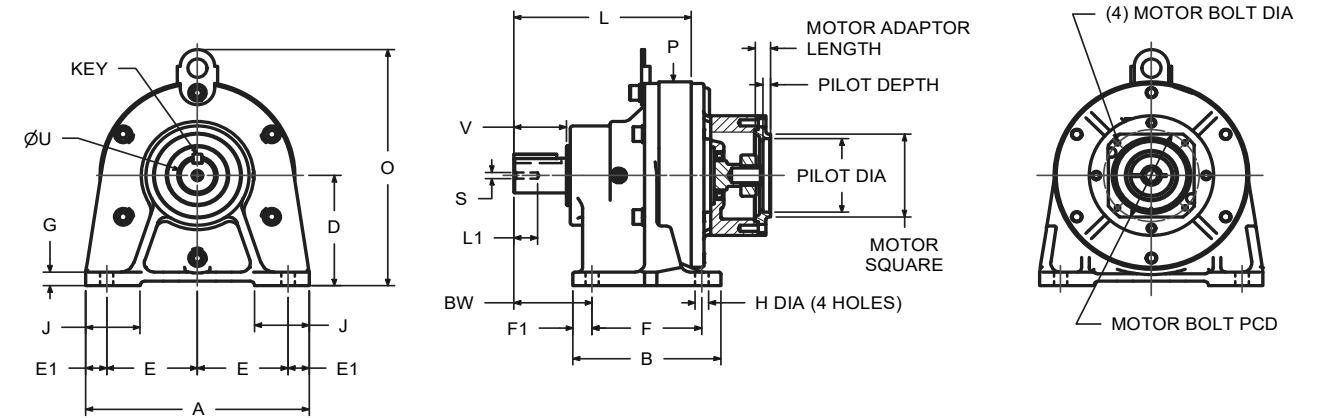
Frame Size	Weight (kg)
606	4.5
607	4.5
609	14
610	14.5
612	29

\* Shaft Tolerances

Shaft Nominal Diameter (inches)	Tolerances (inches)
0.500 (1/2) through 0.625 (5/8)	+0.0000/-0.0004
0.750 (3/4) through 1.125 (1-1/8)	+0.0000/-0.0005
1.250 (1-1/4) through 1.875 (1-7/8)	+0.0000/-0.0006
2.000 (2) through 3.125 (3-1/8)	+0.0000/-0.0007

# Dimensions

## CNHX-6120/5



Dimensions are in inches

Model	A	B	L	D	E	E1	F	F1	G	H	J	O	P	BW
6120/5	9.06	6.10	7.32	4.724	3.74	0.79	4.53	0.79	0.59	0.55	2.17	10.12	8.03	3.23

Model	Low Speed Shaft				
	U <sup>(A)</sup>	V	S	L1	Key
6120/5	1.500	2.17	5/16-18 UNC	0.79	3/8 X 3/8 X 1.77

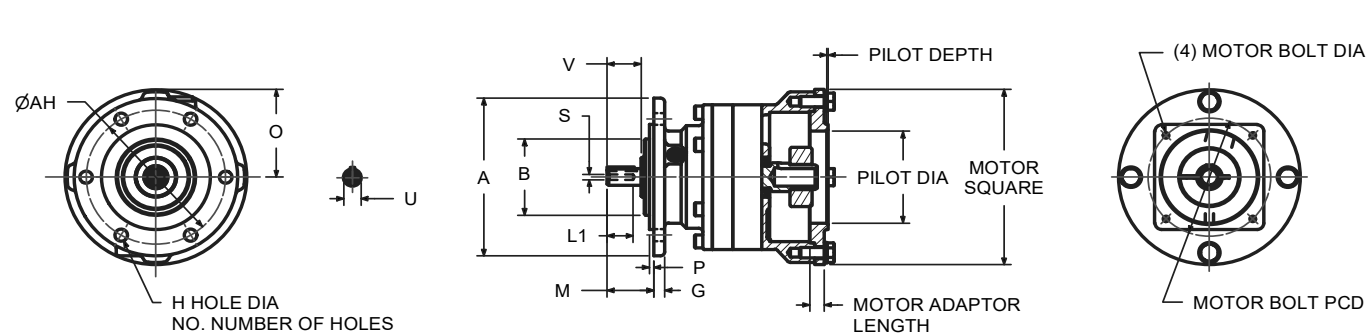
Frame Size	Weight (kg)
606	4.5
607	4.5
609	14
610	14.5
612	29

\* Shaft Tolerances

Shaft Nominal Diameter (inches)	Tolerances (inches)
0.500 (1/2) through 0.625 (5/8)	+0.0000/-0.0004
0.750 (3/4) through 1.125 (1-1/8)	+0.0000/-0.0005
1.250 (1-1/4) through 1.875 (1-7/8)	+0.0000/-0.0006
2.000 (2) through 3.125 (3-1/8)	+0.0000/-0.0007

# Dimensions

## CNVX-6060/5 ▶ 6120/5Y



Dimensions are in inches

Model	A	B	G	H	NO.	M	O	P	AH
6060/5	4.72	3.1484 3.1466	0.31	0.35	6	1.34	-	0.12	4.02
6070/5	6.30	4.3293 4.3272	0.35	0.43	4	1.65	-	0.12	5.28
6080/5	6.30	4.3293 4.3272	0.35	0.43	4	1.89	-	0.12	5.28
6090/5	6.30	4.3293 4.3272	0.35	0.43	4	1.89	4.21	0.12	5.28
6100/5	6.30	4.3293 4.3272	0.35	0.43	4	1.89	4.21	0.12	5.28
6110/5	8.27	5.5101 5.5076	0.43	0.43	6	2.28	4.57	0.16	7.09
6120/5	8.27	5.5101 5.5076	0.51	0.43	6	2.72	5.39	0.16	7.09

Frame Size	Weight (kg)
606	5
607	6
609	13
610	12.5
612	31

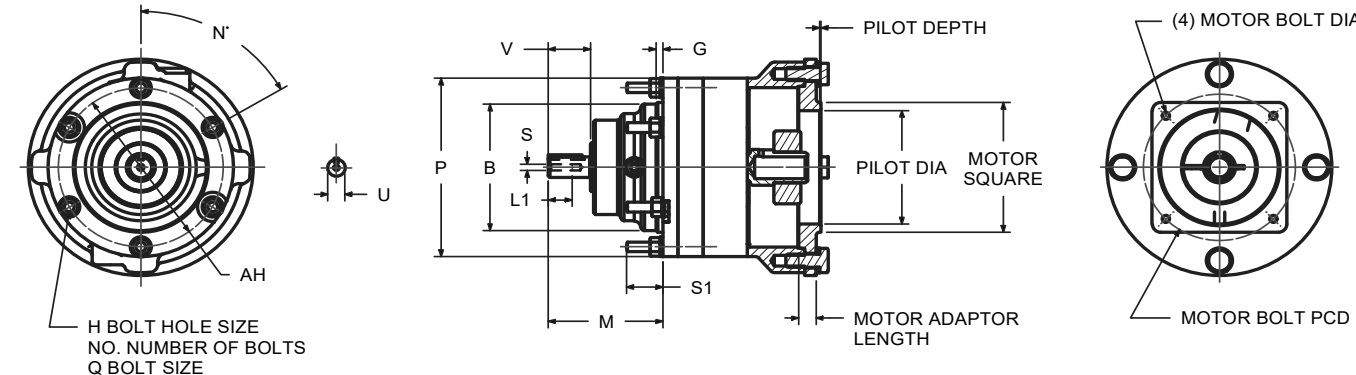
Model	Low Speed Shaft				
	U <sup>(A)</sup>	V	S	L1	Key
6060/5	0.500	0.98	10-32UNF	0.63	1/8 X 1/8 X .79
6070/5	0.750	1.18	12-28UNF	0.63	3/16 X 3/16 X 1.06
6080/5	0.875	1.38	12-28UNF	0.63	3/16 X 3/16 X 1.18
6090/5	1.125	1.38	5/16-18UNC	0.79	1/4 X 1/4 X 1.18
6100/5	1.125	1.38	5/16-18UNC	0.79	1/4 X 1/4 X 1.18
6110/5	1.250	1.77	5/16-18UNC	0.79	1/4 X 1/4 X 1.18
6120/5	1.500	2.17	5/16-18UNC	0.79	3/8 X 3/8 X 1.77

\* Shaft Tolerances

Shaft Nominal Diameter (inches)	Tolerances (inches)
0.500 (1/2) through 0.625 (5/8)	+0.0000/-0.0004
0.750 (3/4) through 1.125 (1-1/8)	+0.0000/-0.0005
1.250 (1-1/4) through 1.875 (1-7/8)	+0.0000/-0.0006
2.000 (2) through 3.125 (3-1/8)	+0.0000/-0.0007
3.250 (3-1/4) through 4.625 (4-5/8)	+0.0000/-0.0009
4.750 (4-3/4) through 7.000 (7)	+0.0000/-0.0010

# Dimensions

## CNFX-6060/5 ▶ 6120/5Y



Dimensions are in inches

Model	B	G	H	NO.	M	N	P	Q	S1	AH
6060/5	3.1492 3.1485	0.16	0.26	6	2.68	60	4.33	M6	0.83	3.86
6070/5	3.1492 3.1485	0.16	0.26	6	2.91	60	4.33	M6	0.83	3.86
6080/5	3.7397 3.7388	0.20	0.35	8	3.58	22.5	5.28	M8	1.06	4.65
6090/5	4.1334 4.1325	0.24	0.35	8	4.49	22.5	5.91	M8	1.14	5.28
6100/5	4.1334 4.1325	0.24	0.35	8	4.49	22.5	5.91	M8	1.10	5.28
6110/5	4.5271 4.5262	0.24	0.35	8	4.65	22.5	6.38	M8	1.02	5.75
6120/5	5.5113 5.5103	0.55	0.43	6	5.47	60	8.03	M10	1.30	7.09

Frame Size	Weight (kg)
606	4.5
607	4.5
609	12
610	11.5
612	28

Model	Low Speed Shaft				
	U <sup>(A)</sup>	V	S	L1	Key
6060/5	0.500	0.98	10-32UNF	0.63	1/8 X 1/8 X .79
6070/5	0.750	1.18	12-28UNF	0.63	3/16 X 3/16 X 1.06
6080/5	0.875	1.38	12-28UNF	0.63	3/16 X 3/16 X 1.18
6090/5	1.125	1.38	5/16-18UNC	0.79	1/4 X 1/4 X 1.18
6100/5	1.125	1.38	5/16-18UNC	0.79	1/4 X 1/4 X 1.18
6110/5	1.250	1.77	5/16-18UNC	0.79	1/4 X 1/4 X 1.18
6120/5	1.500	2.17	5/16-18UNC	0.79	3/8 X 3/8 X 1.77

\* Shaft Tolerances

Shaft Nominal Diameter (inches)	Tolerances (inches)
0.500 (1/2) through 0.625 (5/8)	+0.0000/-0.0004
0.750 (3/4) through 1.125 (1-1/8)	+0.0000/-0.0005
1.250 (1-1/4) through 1.875 (1-7/8)	+0.0000/-0.0006
2.000 (2) through 3.125 (3-1/8)	+0.0000/-0.0007
3.250 (3-1/4) through 4.625 (4-5/8)	+0.0000/-0.0009
4.750 (4-3/4) through 7.000 (7)	+0.0000/-0.0010

---

This page intentionally left blank.

Servo Cyclo®

# 3

# Technical Information

---

# Allowable Radial and Axial Loads

Do not exceed the allowable value for radial and axial load when attaching gear or pulley to the Servo Cyclo.

## Radial and Axial Load of the Slow Speed Shaft

Check the radial and axial load for the slow speed shaft following the formulas 4-6.

Radial load Pr	$Pr = \frac{T\ell}{R} \leq \frac{Pro}{Lf \cdot Cf \cdot Fs}$ [kgf]	Pr : Actual radial load [N, kgf] Tℓ : Actual transmitted torque [N·m, kgf·m] on slow speed shaft of the reducer R : Pitch circle radius [m] of sprocket, gear, pulley, etc. Pro : Allowable radial load [N, kgf] (Refer to the Rating Table) Pa : Actual axial load [N, kgf] Pao : Allowable axial load [N, kgf] (Table 1.8) Lf : Load location factor (Table 1.7) Cf : Coupling factor (Table 1.5) Fs : Shock factor (Table 1.6)
Axial load Pa	$Pa \leq \frac{Pao}{Cf \cdot Fs}$ [kgf]	
When radial and axial load coexists	$\left( \frac{Pr \cdot Lf}{Pro} + \frac{Pa}{Pao} \right) \cdot Cf \cdot Fs \leq 1$	

Table 1.5 Coupling Factor Cf

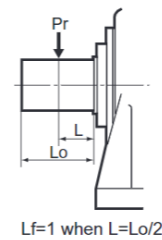
Coupling Method	Cf
Chain	1
Gears	1.25
V-Belt	1.5

Table 1.6 Shock Factor Fs

Degree of Shock	Fs
Practically No Shock	1
Light Shock	1 ~ 1.2
Severe of Shock	1.4 ~ 1.6

Table 1.7 Load Location Factor Lf on Slow Speed Shaft

Frame Size	LMM									
	-5	10	15	20	25	30	35	40	45	50
6060 6065	0.83	0.94	1.19	1.56	-	-	-	-	-	-
6070 6075	0.82	0.91	1.00	1.29	1.59	1.88	-	-	-	-
6080 6085	0.81	0.87	0.94	1.03	1.28	1.54	1.80	-	-	-
6090 6095	0.86	0.92	0.97	1.13	1.38	1.64	1.90	-	-	-
6100 6105	0.86	0.92	0.97	1.13	1.38	1.64	1.90	-	-	-
6110 6115	0.78	0.84	0.90	0.96	1.02	1.08	1.19	1.36	1.53	-
6120 6125	-	0.82	0.87	0.92	0.97	1.08	1.25	1.42	1.59	1.76



# Allowable Radial and Axial Loads

Table 1.8 Allowable Axial Load Pao on Slow Speed Shaft [N] / [kgf]

Frame Size	Output Speed r/min															
	-10	15	20	25	30	35	40	50	60	80	100	125	150	200	250	50
6060 6065	294.3 30	294.3 30	294.3 30	294.3 30	294.3 30	294.3 30	294.3 30	294.3 30	294.3 30	294.3 30	294.3 30	294.3 30	294.3 30	294.3 30	-	-
6070 6075	784.8 80	784.8 80	784.8 80	784.8 80	784.8 80	784.8 80	784.8 80	784.8 80	784.8 80	784.8 80	784.8 80	784.8 80	784.8 80	784.8 80	784.8 80	784.8 80
6080 6085	981 100	981 100	981 100	981 100	981 100	981 100	981 100	981 100	981 100	981 100	981 100	981 100	981 100	981 100	981 100	981 100
6090 6095	981 100	981 100	981 100	981 100	981 100	981 100	981 100	981 100	981 100	981 100	981 100	981 100	981 100	981 100	981 100	981 100
6100 6105	1470 150	1470 150	1470 150	1470 150	1470 150	1470 150	1470 150	1470 150	1470 150	1470 150	1470 150	1470 150	1470 150	1470 150	1470 150	1470 150
6110 6115	1470 150	1470 150	1470 150	1470 150	1470 150	1470 150	1470 150	1470 150	1470 150	1470 150	1470 150	1470 150	1470 150	1470 150	1470 150	1470 150
6120 6125	2940 300	2940 300	2940 300	2940 300	2940 300	2940 300	2940 300	2940 300	2940 300	2940 300	2940 300	2940 300	2940 300	2940 300	2940 300	2940 300

Calculate detailed intermediate value using interpolation method as below.

[Example of Interpolation Method Calculation]

Radial Load location factor

Radial load location factor of slow speed shaft for frame size 6075 with L= 18mm is:

$$1.00 + \frac{1.29 - 1.00}{20 - 15} \times (18 - 15) = 1.17$$

Allowable axial load

Allowable axial load of slow speed shaft for frame size 6125 with output speed 180 r/min is:

$$282 + \frac{300 - 282}{200 - 150} \times (200 - 180) = 289 \text{ [kgf]}$$

# Inertia

Inertia for Servo Cyclo® Motors differ according to frame size, reduction ratio, and the shaft diameter of the servo motor used. Inertia for Servo Cyclo® Motors is calculated by adding  $GD_1^2$  and  $GD_2^2$

$$GD^2 = GD_1^2 + GD_2^2 \text{ [kgf}\cdot\text{m}^2\text{]} \text{ (Formula 7)}$$

$GD^2$ :  $GD^2$  of Servo Cyclo Motor [kgf·m<sup>2</sup>]

$GD_1^2$ :  $GD^2$  determined by frame size and reduction ratio [kgf·m<sup>2</sup>]

$GD_2^2$ :  $GD^2$  determined by shaft diameter of servo motor [kgf·m<sup>2</sup>]

**Table 1.9 Inertia Determined by Frame Size and Reduction Ratio (x 10<sup>-4</sup>kgf·m<sup>2</sup>)**

Frame Size	Reduction Ratio							
	6	11	15	21	29	43	59	87
6060 6065	-	0.449	0.407	0.379	0.361	0.351	-	-
6070 6075	0.682	0.454	0.409	0.379	0.362	0.351	0.346	-
6080 6085	1.61	1.12	1.02	0.688	0.650	0.380	0.370	0.363
6090 6095	3.87	2.41	1.99	1.19	1.35	1.04	0.779	0.768
6100 6105	3.13	1.41	0.844	0.593	0.709	0.630	0.586	0.568
6110 6115	5.99	3.38	2.88	2.44	2.31	2.19	2.12	2.09
6120 6125	12.6	6.45	3.87	2.98	3.84	3.51	3.36	3.25

Note: Divide by 4g (4 x 9.8m/s<sup>2</sup>) to convert  $GD^2$  to moment of inertia.

**Table 1.10 Inertia Determined by Shaft Diameter of Servo Motor (x 10<sup>-4</sup>kgf·m<sup>2</sup>)**

Frame Size	Shaft Diameter								
	φ11	φ14	φ16	φ19	φ22	φ24	φ28	φ32	φ35
6060 6065	0.484	0.423	-	-	-	-	-	-	-
6070 6075	0.487	0.426	0.471	-	-	-	-	-	-
6080 6085	0.560	0.489	0.542	3.450	3.460	-	-	-	-
6090 6095	0.594	0.534	0.579	3.98	4.20	4.20	-	-	-
6100 6105	0.604	0.543	0.589	3.99	4.21	4.21	9.23	-	11.6
6110 6115	0.876	0.808	0.860	4.46	4.72	4.69	9.65	-	-
6120 6125	1.98	1.88	1.97	4.90	5.12	5.04	10.2	12.5	12.6

Note: Divide by 4g (4 x 9.8m/s<sup>2</sup>) to convert  $GD^2$  to moment of inertia.

# Lubrication


1. Filled with long-lifetime grease, the Servo Cyclo® Series require infrequent lubricant replacement. However replacement every 20,000 hours or every 4 to 5 years will provide an even longer lifetime.
2. Do not use grease other than the ones indicated in Table 4.7a.
3. Consult us when operating constantly at temperature range exceeding -10 - 50°C

## Approved Greases

Grease lubricated reducers are filled with grease prior to shipment and are ready for installation and operation. This information is provided for maintenance purposes.

**Table 1.11a Approved Greases**

Ambient Temperature		Cycloid Discs
°F	°C	ExxonMobil
14 to 122	-10 to 50	Exxon Unirex N2 Grease (NLGI Grade #2)



When the Servo Cyclo® gearbox will be used under widely fluctuating temperatures or ambient temperatures (other than those listed here) or any other special conditions, consult the factory.

**Table 1.12a Grease Fill Quantities for Maintenance Free Speed Reducers**

Units are in ounces (grams)

Frame Size	606X	607X	608X	609X	610X	611X	612X
<b>Speed Reduction Mechanism (1st stage)</b>	0.9 (25)	0.9 (25)	2.3 (65)	3.2 (90)	4.9 (140)	7.1 (200)	11.6 (330)
<b>Slow Speed Shaft Bearing</b>	1.2 (35)	1.2 (35)	2.5 (70)	3.5 (100)	3.5 (100)	3.2 (90)	4.2 (120)

For use in winter or relatively low ambient temperatures, use the lower viscosity oil specified for each ambient temperature range.

For consistent use in ambient temperatures outside of the range 32°F to 104°F (0°C to 40°C), consult factory.

**Table 1.12b Optional Greases**

Application	Temperature Range		Grease Manufacturer	Brand	NGLI Grade	Cyclo Frame Size
	°F	°C				
<b>Food Grade</b>	14 to 104	-10 to 40	Ultrachem	Omnilube FGM	2	606X to 612X
<b>Low Temperature</b>	-40 to 30	-40 to -1 <sup>[1]</sup>	ExxonMobil	Beacon 325	2	All
			Anderol	Royco 22 CF	2	All
<b>High Temperature</b>	105 to 180	40 to 80	ExxonMobil	Unirex N	2	All

NOTE: All units filled with grease other than Standard won't be considered Maintenance Free.

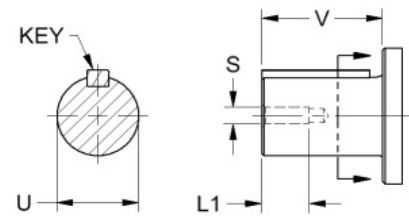
[1]: Consult factory for temperatures outside the established range.



# Low Speed Shaft Specifications

# Industry Packages

## Metric DIN Style "G"

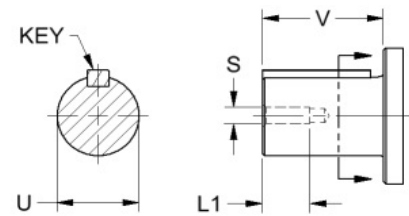


All dimensions are in mm

Size	Type	ØU	Tolerance	V	S	L1	Key Dimensions
606 X	G	14 k6	+0.012 +0.001	25	M5	16	5 x 5 x 20
607 X	G	19 k6	+0.015 +0.002	30	M6	16	6 x 6 x 25
608 X	G	22 k6	+0.015 +0.002	35	M6	16	6 x 6 x 30
609 X	G	28 k6	+0.015 +0.002	35	M8	20	8 x 7 x 32
610 X	G	28 k6	+0.015 +0.002	35	M8	20	8 x 7 x 32
611 X	G	32 k6	+0.018 +0.002	45	M8	20	10 x 8 x 37
612 X	G	38 k6	+0.018 +0.002	55	M8	20	10 x 8 x 50

X = 0 or 5; single stage and multistage

## Metric JIS

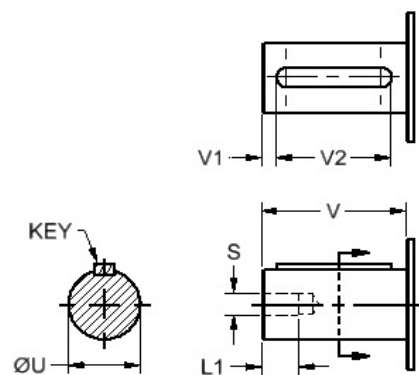


All dimensions are in mm

Size	Type	ØU	Tolerance	V	S	L1	Key Dimensions
606 X	-	14 h6	+0/-0.011	25	M5	16	5 x 5 x 20
607 X	-	18 h6	+0/-0.011	30	M6	16	6 x 6 x 25
608 X	-	22 h6	+0/-0.013	35	M6	16	6 x 6 x 30
609 X	-	28 h6	+0/-0.013	35	M8	20	8 x 7 x 32
610 X	-	28 h6	+0/-0.013	35	M8	20	8 x 7 x 32
611 X	-	32 h6	+0/-0.016	45	M8	20	10 x 8 x 37
612 X	-	38 h6	+0/-0.016	55	M8	20	10 x 8 x 50

X = 0 or 5; single stage and multistage

## Metric DIN Style "E"



All dimensions are in mm

Size	Type	ØU	Tolerance	V	S	L1	Key Dimensions	V <sub>1</sub>	V <sub>2</sub>
606 X	E	14 k6	+0.012 +0.001	30	M5	16	5 x 5 x 20	2.5	25
607 X	E	20 k6	+0.015 +0.002	40	M6	16	6 x 6 x 25	4	32
608 X	E	25 k6	+0.015 +0.002	50	M10	20	6 x 6 x 30	3.5	40
609 X	E	25 k6	+0.015 +0.002	50	M10	20	8 x 7 x 32	3.5	40
610 X	E	30 k6	+0.015 +0.002	60	M10	20	8 x 7 x 32	3.5	50
611 X	E	35 k6	+0.018 +0.002	70	M12	20	10 x 8 x 37	7	56
612 X	E	35 k6	+0.018 +0.002	70	M12	24	10 x 8 x 50	7	56

X = 0 or 5; single stage and multistage

Four food-grade packages are available for use in machinery where there is incidental food contact. (Chemi SHIELD, SHIELD360, Food-Grade, and Ultra SHIELD360)

The food-grade optional packages are available for Servo Cyclo® frame sizes 6060 through 6125.

When ordering, choose the Special Specification Code (SSC) that meets your requirements to obtain the features listed below.

Modification	Chemi SHIELD360	Chemical Duty	Mill Duty	Low Temp	High Temp	Weather Proof IP54	Wash-down IP55	SHIELD360	Food-Grade	Ultra SHIELD360
Sever Duty Breather	✓	✓	✓			✓	✓			✓
Epoxy Paint		✓	✓				✓			
FDA Epoxy Paint									✓	
FDA White Acrylic Top Coat								✓		
FDA Stainless Grey Acrylic Top Coat	✓	✓								
FDA Stainless Grey Epoxy Clear Top										✓
FDA Grease/Oil								✓	✓	✓
Low Temp Grease/Oil				✓						
High Temp Grease/Oil					✓					
Double Output Seals			✓				✓			
Polyacrylate High Temp Seals					✓					
Low Temperature Seals				✓						
FKM AM & Chemical	✓	✓								✓
Stainless Steel or Zinc Hardware										✓
Stainless or Tesa Nameplate	✓	✓								✓
Stainless Steel Output Shaft	✓									✓
High Capacity Bearing			✓							
Shoulder Bolts or Dowel Pins			✓							
Modified Oil Gauge										
Ductile Iron Housing			✓							

Stainless Steel Solid Shaft - maximum torque ratings with standard solid shaft diameters are the same as those listed in this catalog for standard models. Consult the factory when ordering smaller than standard diameters, or if there will be overhung load.

\* UltraShield360™ available in quill input option only

Low Temp Package = -30 degrees C Maximum. For lower temperature requirements consult factory.

High Temp Package = 50 degrees C Maximum. For higher temperature requirements consult factory.

# Installation

## 1. Assembly with a Keyless Type Motor

1. Wipe servo motor shaft and inside of high speed shaft of Cyclo Drive to remove all traces of oil and dust. (Rustproof oil is applied to the inside of high speed shaft at the time of shipment.)
2. Place the reducer on an appropriate platform with the slow speed shaft on the bottom side.
3. Match the cut of the high speed shaft and the clamp ring.
4. Remove the cap of the adapter plate. Insert a hexagon wrench into the hexagon socket head bolt through the assembly opening. Without removing the hexagon wrench, insert the shaft of the servo motor into the high speed shaft.
5. Make sure that the spigot of the servo motor and the adapter plate is fitting each other properly. Tighten motor attachment bolt to connect servo motor and adapter plate. Do not tighten bolt when spigots do not fit properly. Assembly will be uneven, which may damage the internal bearing.
6. Tighten hexagon socket head bolt of the clamp ring with the torque indicated in Table 1.13.
7. Operate at slow speed for some time. Tighten again with torque indicated in Table 1.13.
8. Attach the cap of the adapter plate with was removed in the earlier step.

Table 1.13 Tightening Torque for Hexagon Socket Head Bolt on the Clamp Ring

Bolt Size	M4	M5	M6	M8	M10	M12
Tightening Torque (Nm)	4.3	5.5	9.6	23	46	79

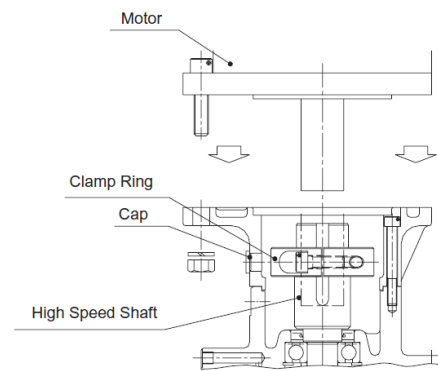


Fig. 4. Assembly Diagram

## 2. Assembly with a Key Type Motor

1. Apply fretting prevention to the servo motor shaft and Cyclo Drive high speed shaft hole before assembly
2. Take sufficient care for shaft center alignment when assembling servo motor and Cyclo Drive.
3. Always make sure that the spigot of the servo motor fits the spigot of the adapter plate properly. Then tighten motor attachment bolt to connect servo motor and adapter plate. Do not tighten bolt when spigots do not fit properly. Assembly will be uneven, which may damage the internal bearing.

# Warranty

Company warrants that (i) all new equipment and parts (collectively, "Equipment") sold by Company will conform to printed drawings and specification sheets issued by Company and (ii) are free of defects in material and workmanship for the time period shown in Table 1.14. The warranty period commences on the date of shipment of the Equipment by Company.

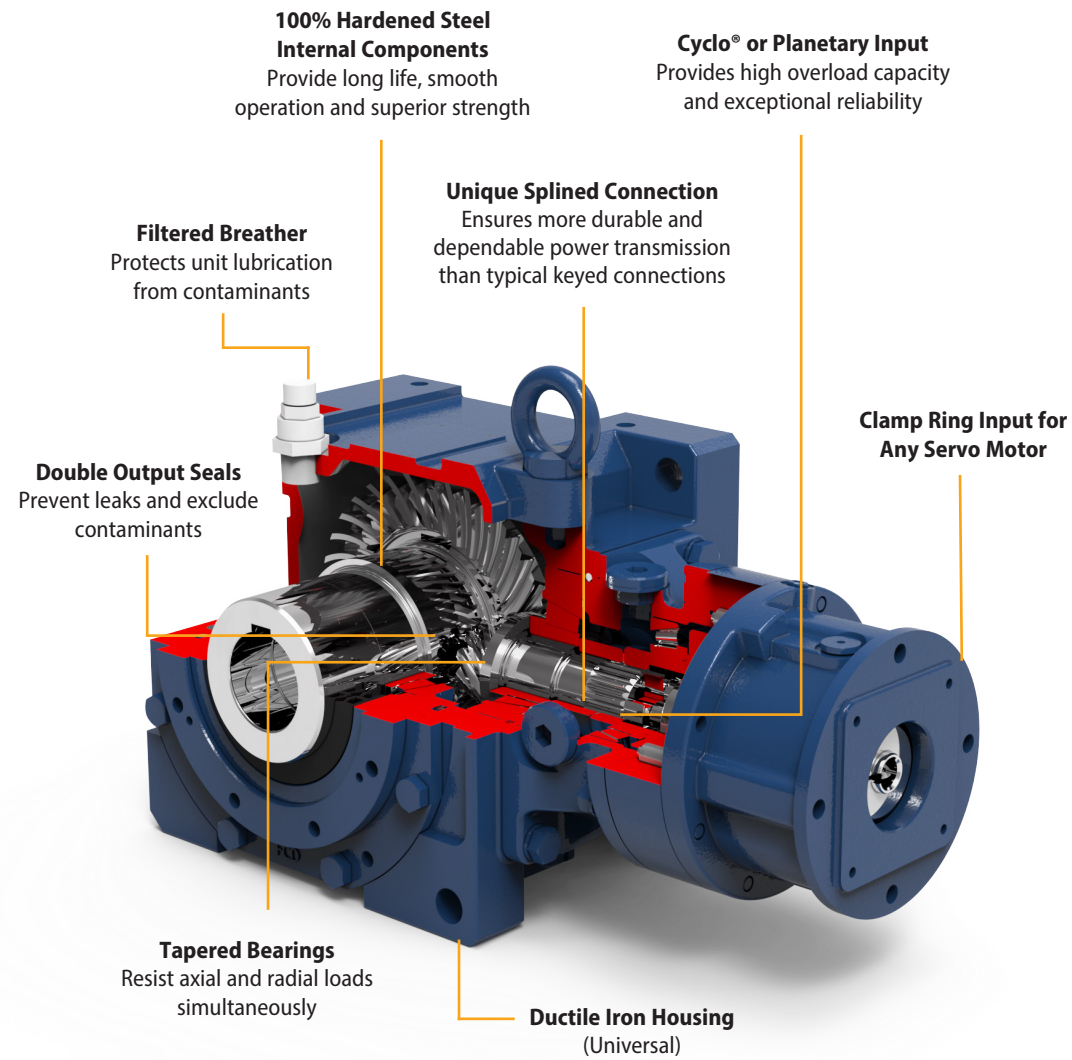
If, within the warranty period, Company receives from Buyer written notice of any alleged defect in any of the Equipment and, if the Equipment is found by Company not to conform with these warranties (after Buyer has provided Company a reasonable opportunity to perform any appropriate tests on the allegedly defective Equipment), Company will, at its sole option and expense, either repair or replace the Equipment. In all instances, Company reserves the right to require Buyer to deliver the Equipment for repair or replacement to a designated service center and require Buyer to pay all charges for inbound and outbound transportation and for services of any kind, diagnostic or otherwise, excepting only the direct and actual cost of Equipment repair or replacement. Warranty coverage is limited to parts and labor and does not include travel and other expenses. Buyer applications and use of the Equipment may require installation of safety features. Buyer is responsible for furnishing and installing guards or other safety equipment needed to protect operating personnel, even though such equipment may not be furnished by Company with the Equipment purchased. Equipment supplied, but not manufactured, by Company is warranted only to the extent of the original manufacturer's warranty.

Table 1.14 - Product Warranty

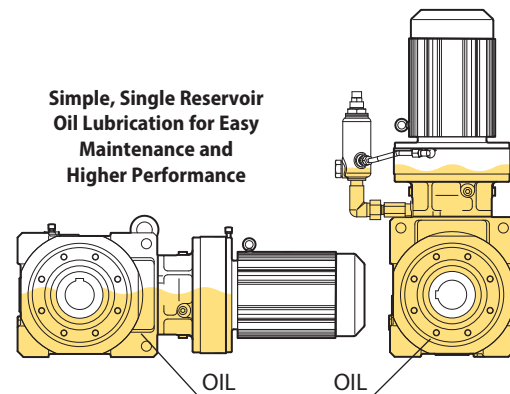
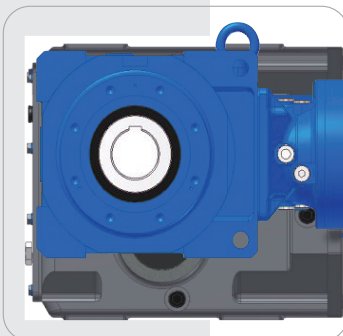
Product	Warranty Period (After Shipment)	Components Excluded
Cyclo® Speed Reducers	2 Years	Bearings and Seals
Cyclo® Bevel Buddybox Speed Reducers	2 Years	Bearings and Seals
Cyclo® Bevel Buddybox H Speed Reducers	2 Years	Bearings and Seals
Fine Cyclo® Speed Reducers	2 Years	Bearings and Seals
ECY Elastic Cyclo®	2 Years	Bearings and Seals
Hyponic® Speed Reducers and Gearmotors	2 Years	Bearings and Seals
IB Series Servo Gearheads	1 Year	Bearings and Seals
Parts	1 Year	---
Repairs	1 Year	Bearings and Seals

## ► Flexible configurations

- **Shaft Options:**  
Keyed Hollow  
Shrink Disc  
Solid Shaft  
(Keyless) Taper-Grip® Bushing
- **Mounting Options:**  
Flange  
Foot  
Shaft  
Universal Housing



More Compact, Space-Saving Design Than Typical Right-Angle Gearboxes



## Product Description

The Servo BBB built by Sumitomo is a robust, state of the art mid-sized all steel family of speed reducers and gearmotors. Building on more than 75 years of successful Cyclo® experience in virtually every application and industry, The result is an extremely compact, efficient and reliable unit in a very power-dense package. The Servo BBB is a unique combination of features that results in a highly reliable, efficient and durable gearbox. The all-steel internal construction, in conjunction with the Cyclo® gear inputs, and ductile iron housing provide unmatched ruggedness. In addition, the full array of output mounting styles provides an amazing ability to customize the product to fit nearly any requirement. These options include solid shaft, hollow bore, and shrink disc.

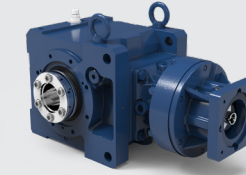
## Features & Benefits

- **100% Hardened Steel Rotating Components**  
~ Provide high efficiency, long life and exceptional reliability
- **Cycloidal Input**  
~ Unmatched capability to handle overloads
- **Double Output Seals**  
~ Four seal lips on every unit virtually eliminates the possibility of leaks
- **Dimensionally Interchangeable with BBB3**  
~ Simple, economical retrofits
- **Patented Taper-Grip® Bushing**  
~ Simple, keyless shaft mounting
- **Two Year Warranty**  
~ Not limited by hours of operation or duty cycles
- **Up to 95% Efficiency**

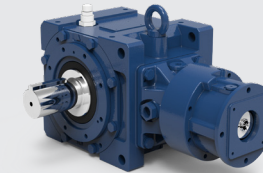
## General Specifications Summary

**Ratios:** 21:1 to 305:1 and greater  
**Torque Capacity:** 2,140 N·m. (18,941 in·lbs)  
**HP:** 0.32 to 7.51 kW  
**Mounting:** Output Shaft, Foot, Flange, Face  
**Options:** Shrink Disc

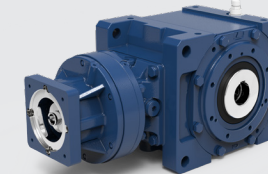
## ► Popular Input and Output Options



Taper-Grip® Bushing  
Inch and Metric Sizes



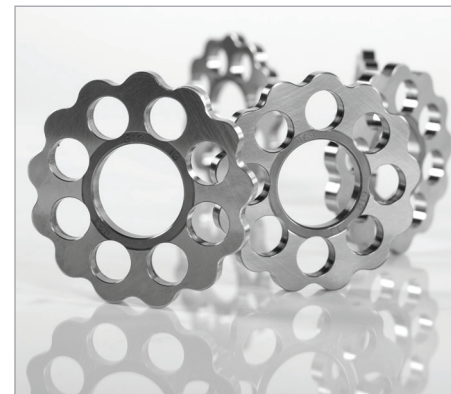
Solid Output Shaft  
Inch and Metric Sizes



Keyed Hollow Bore  
Inch and Metric Sizes



Shrink Disk  
Inch and Metric Sizes



## Cyclo® Quality and Reliability, Right Angle Design

- High performance steel input components deliver **up to 94% efficiency**
- Cycloidal technology offers **reliable operation, long life and high shock load capacity**

# FAQs

### How do I select a Servo BBB4 gearbox?

Selection is based on the actual speed and torque requirements at the output shaft. The Servo BBB4 gearbox has particularly high efficiencies over a wide range of reduction ratios, which frequently permits the use of reduced input power requirements (smaller kW motor) without sacrificing output shaft torque. The selection procedures in this catalog will guide you in choosing the most efficient reducer for your application.

### How can I be sure that the reducer can withstand periodic excessive overloads?

Servo BBB4 gearboxes can provide solutions with extraordinary shock load capabilities. For applications with high shock loads, consult a Sumitomo Applications Engineer.

### What thermal capacity limitations does the Servo BBB4 have?

The Servo BBB4, by virtue of its smooth, almost frictionless operation (unlike traditional helical gears), has a thermal rating that far exceeds its mechanical capacity and all but eliminates the conventional limitations due to heat.

### What are the advantages of the Taper-Grip® bushing?

The Taper-Grip® bushing is integral to the Servo BBB4 and provides for easy mounting and removal to and from the shaft of the driven machine. Because it requires no keyway, the shaft isn't weakened and maximum torque is transmitted.

### What are the advantages of a shrink disc?

The shrink disc provides for easy mounting and removal to and from the shaft of the driven machine. Because it requires no keyway, the shaft isn't weakened and maximum torque is transmitted.

### What kind of torque arm do I specify? At what position should I mount it?

The standard torque arm assembly supplied is a Turnbuckle type as shown on page 2.43. The torque arm should be mounted at 90 degrees to a line from the point of attachment to the reducer and the center of the output bore with up to 30 degrees plus or minus variance. A bracket type torque arm is also offered as a non-stock option.

# Standard Specifications

## Reducer

Reduction:	Combination of Servo Cyclo® input and right angle spiral bevel gear output.
Lubrication:	In all mounting configurations except Y4, the Cyclo portion is grease lubricated and the bevel portion is oil lubricated.
Seals:	Nitrile material, dual lipped.
Material:	Rugged ductile cast iron housings in all sizes.
Paint Color:	Blue, Munsell color number 6.5PB 3.6/8.2
Bearings:	Tapered roller bearings on geared output of all sizes. Ball bearings on Cyclo® input.

## Ambient Conditions

Installation Location:	Indoors (Minimal dust and humidity)
Ambient Temperature:	14°~104° F (-10° ~ 40° C)
Ambient Humidity:	Under 85%
Elevation:	Under 1,000 meters (3,281 ft.)
Atmosphere:	Well ventilated location, free of corrosive gases, explosive gases, vapors and dust.

## Shaft Rotation

Servo BBB4 speed reducers, ratios 21 through 305, the slow speed shaft rotates in a reverse direction to that of the high speed shaft.

## Thermal Capacity

The Servo BBB4 speed reducer's smooth, almost frictionless operation all but eliminates the conventional limitations due to heat. In all sizes, Servo BBB4 speed reducers have thermal ratings that exceed their mechanical capacity.

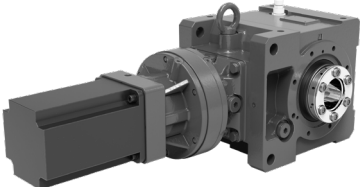
# Optional Nominal and Exact Ratios

		Single Reduction										
Nominal Ratio	Overall	19	26	42	48	54	93	138	163	189	227	278
	Input	6	8	13	15	17	29	43	51	59	71	87
Exact Ratio	Overall	19.2	25.6	41.6	48	54.4	92.8	137.6	163.2	188.8	227.2	278.4
	Input	6	8	13	15	17	29	43	51	59	71	87

# Mounting Positions

Note: 1. Mounting positions are shown with standard (Taper Grip Bushing) output option.  
2. The plane of reference represents the location of customer's equipment.

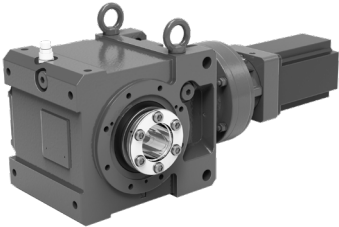
Y1



Y2



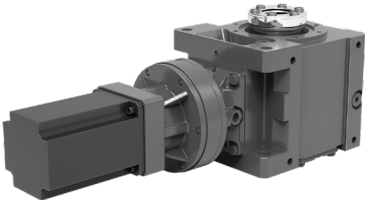
Y3



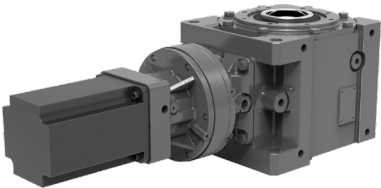
Y4



Y5



Y6



---

# 2

# How to Configure

---

# Configure a Model Number

# Nomenclature

### Output Shaft Orientation

Type	Prefix
Horizontal	H
Vertical	V

### Mounting Style

Type	Prefix
Shaft Mount (Hollow Shaft)	Y
Housing Mount (Solid Shaft)	U
Flange (Solid Shaft)	F
Foot (Solid Shaft)	H

### Input Connection

Input Connection	Prefix	
	Reducer	Motor
W/Input Motor Flange & Hollow Bore	X	XM




### Modification

	Prefix
Unit build with special modifications	S
Shrink Disc	S
No special modifications applied	

### Frame Size

Single Reduction
4A100
4A105
4A110
4A115
4A120
4A125
4B120
4B125

### Output Shaft Direction (Shafted Model Only)

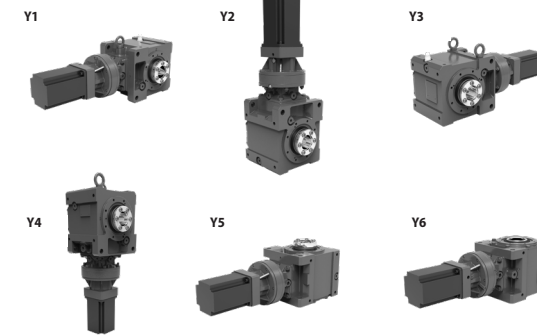
Projects to Left Side	L	
Projects to Right Side	R	
Projects to Both Left/Right Sides	T	

### Shaft Specifications

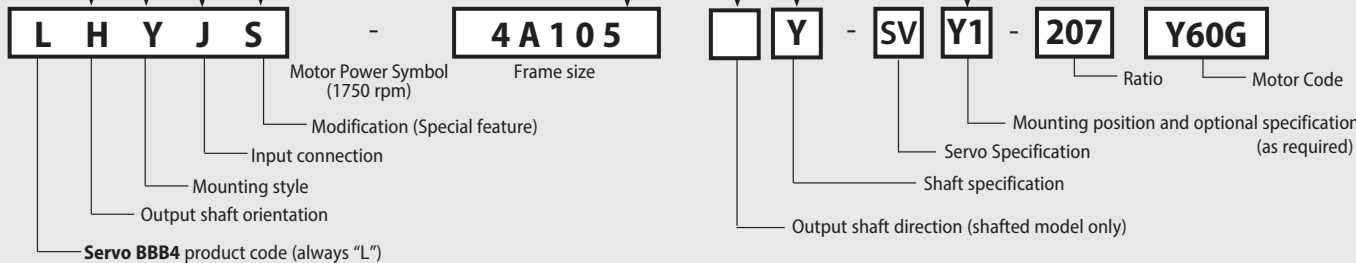
Input Shaft	OUTPUT SHAFT		Suffix
	Hollow	Solid	
mm	Key (mm)	mm	
Inch	Key (Inch)	Inch	K
mm	Taper-Grip®		M
Inch	Taper-Grip®		Y

### BBB4 with Cyclo Input

Single Reduction Input
Overall Nominal Ratio
21
22
25
28
35
39
46
53
60
67
74
80
88
102
112
123
151
179
207
249
305



### Mounting Positions



**Nomenclature Example:**  
**LHYJS - 4A105Y - SVY1 - 207 Y60G**

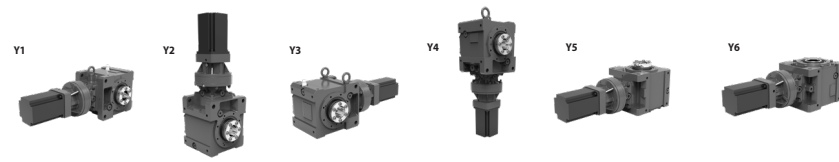
L – Servo Bevel Buddybox	4A105 – Frame Size
H – Horizontal Output Shaft	Y – Taper-Grip® Bushing output, inch shaft input
Y – Shaft Mount (Hollow Shaft)	SV – Servo Specification
J – C-Face Input	Y1 – Installation Position
S – Modification (Special feature)	207 – Ratio

Servo BBB

Servo BBB

# Rating Tables

# Rating Tables



Size	Ratio	Input Speed												Allowable Max Input Speed r/min	Allowable Peak Torque at Startup and Stop N·m
		1000 r/min				1500 r/min				1750 r/min					
		Allowable Input Power kW	Rated Output Torque N·m	Allowable Radial Load N	Max %ED	Allowable Input Power kW	Rated Output Torque N·m	Allowable Radial Load N	Max %ED	Allowable Input Power kW	Rated Output Torque N·m	Allowable Radial Load N	Max %ED		
4A100	21	2.35	435	22703	100	2.35	291	20650	100	2.35	248	19900	100	3600	580
	22	-	-	-	-	-	-	-	-	-	-	-	-	-	-
	25	-	-	-	-	-	-	-	-	-	-	-	-	-	-
	28	2.35	581	24203	100	2.35	388	22133	100	2.35	331	21300	100	3600	849
	35	2.35	730	23886	100	2.35	488	23333	100	2.35	416	22500	100	3600	776
	39	2.35	799	23151	100	2.35	533	23750	100	2.35	455	23000	100	3600	849
	46	2.11	845	22565	100	2.35	630	24550	100	2.35	537	23800	100	3600	849
	53	1.84	849	22500	100	2.35	727	23850	100	2.35	620	24600	100	3600	849
	60	1.62	849	22500	100	1.99	697	24183	100	1.99	594	25100	100	3600	849
	67	1.32	776	23400	100	1.91	755	23600	100	1.93	651	24600	100	3600	776
	74	1.32	849	22500	100	1.91	826	22767	100	1.93	712	24100	100	3600	849
	80	1.1	775	23411	100	1.27	599	25033	100	1.27	511	25700	100	3600	776
	88	1.1	848	22522	100	1.27	656	24567	100	1.27	559	25400	100	3600	849
	102	0.95	849	22500	100	1.21	725	23900	100	1.21	618	24900	100	3600	849
	112	0.79	776	23400	100	0.98	644	24667	100	0.98	549	25500	100	3600	776
	123	0.79	849	22500	100	0.98	704	24100	100	0.98	601	25100	100	3600	849
	151	0.64	849	22500	100	0.78	693	24267	100	0.78	591	25100	100	3600	849
	179	0.53	839	22619	100	0.56	590	25133	100	0.56	503	25800	100	3600	849
207	0.46	844	22565	100	0.52	629	24850	100	0.52	536	25600	100	3600	849	
249	0.39	846	22543	100	0.44	639	24750	100	0.44	545	25500	100	3600	849	
305	0.32	849	22500	100	0.43	778	23333	100	0.43	664	24500	100	3600	849	

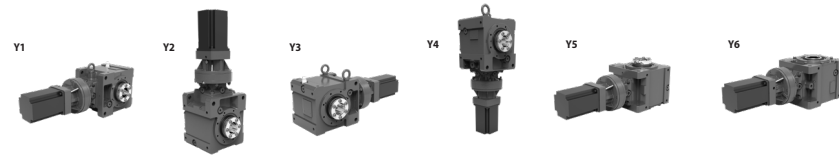
Size	Ratio	Input Speed												Allowable Max Input Speed r/min	Allowable Peak Torque at Startup and Stop N·m
		2000 r/min				2500 r/min				3000 r/min					
		Allowable Input Power kW	Rated Output Torque N·m	Allowable Radial Load N	Max %ED	Allowable Input Power kW	Rated Output Torque N·m	Allowable Radial Load N	Max %ED	Allowable Input Power kW	Rated Output Torque N·m	Allowable Radial Load N	Max %ED		
4A100	21	2.35	223	19233	100	2.35	174	17900	100	2.35	145	17100	100	3600	580
	22	-	-	-	-	-	-	-	-	-	-	-	-	-	-
	25	-	-	-	-	-	-	-	-	-	-	-	-	-	-
	28	2.35	298	20633	100	2.35	232	19300	100	2.35	193	18400	100	3600	849
	35	2.35	374	21800	100	2.35	291	20400	100	2.35	243	19500	100	3600	776
	39	2.35	410	22267	100	2.35	319	20800	100	2.35	266	19900	100	3600	849
	46	2.35	484	23067	100	2.35	377	21600	100	2.35	314	20700	100	3600	849
	53	2.35	558	23833	100	2.35	435	22300	100	2.35	362	21400	100	3600	849
	60	1.99	535	24533	100	1.99	417	23400	100	1.99	348	22400	100	3600	849
	67	1.93	586	24433	100	1.93	457	24100	100	1.93	381	23100	100	3600	776
	74	1.93	641	24233	100	1.93	500	24500	100	1.93	416	23600	100	3600	849
	80	1.27	460	25867	100	1.27	358	26200	100	1.27	298	25000	100	3600	776
	88	1.27	503	25733	100	1.27	391	26400	100	1.27	326	25600	100	3600	849
	102	1.21	556	25333	100	1.21	433	26200	100	1.21	360	26600	100	3600	849
	112	0.98	494	25800	100	0.98	385	26400	100	0.98	321	26700	100	3600	776
	123	0.98	541	25500	100	0.98	421	26300	100	0.98	351	26600	100	3600	849
	151	0.78	532	25500	100	0.78	413	26300	100	0.78	345	26600	100	3600	849
	179	0.56	453	26067	100	0.56	352	26600	100	0.56	293	26800	100	3600	849
207	0.52	482	25900	100	0.52	375	26500	100	0.52	313	26800	100	3600	849	
249	0.44	491	25833	100	0.44	382	26500	100	0.44	318	26700	100	3600	849	
305	0.43	597	25000	100	0.43	464	26000	100	0.43	387	26400	100	3600	849	

Notes: [1] For selections noted with \*, the duty cycle for units mounted in the Y2 configuration is limited to 75% Equivalent Duty (10 minute cycle time).



# Rating Tables

# Rating Tables

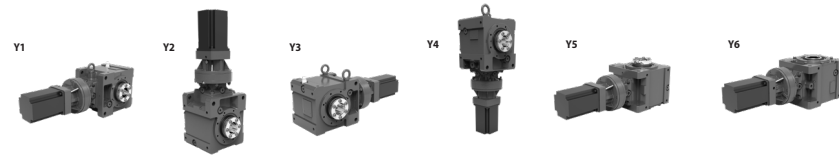


Size	Ratio	Input Speed				Allowable Max Input Speed r/min	Allowable Peak Torque at Startup and Stop N·m
		3600 r/min					
		Allowable Input Power kW	Rated Output Torque N·m	Allowable Radial Load N	Max %ED %		
4A100	21	2.35	121	16300	100	3600	580
	22	-	-	-	-	-	-
	25	-	-	-	-	-	-
	28	2.35	161	17600	100	3600	849
	35	2.35	202	18700	100	3600	776
	39	2.35	221	19100	100	3600	849
	46	2.35	262	19900	100	3600	849
	53	2.35	302	20500	100	3600	849
	60	1.99	290	21500	100	3600	849
	67	1.93	317	22200	100	3600	776
	74	1.93	347	22600	100	3600	849
	80	1.27	248	23900	100	3600	776
	88	1.27	272	24500	100	3600	849
	102	1.21	300	25500	100	3600	849
	112	0.98	267	26500	100	3600	776
	123	0.98	292	26800	100	3600	849
	151	0.78	287	26900	100	3600	849
	179	0.56	244	27000	100	3600	849
207	0.52	261	26900	100	3600	849	
249	0.44	265	26900	100	3600	849	
305	0.43	322	26700	100	3600	849	

Size	Ratio	Input Speed												Allowable Max Input Speed r/min	Allowable Peak Torque at Startup and Stop N·m
		1000 r/min				1500 r/min				1750 r/min					
		Allowable Input Power kW	Rated Output Torque N·m	Allowable Radial Load N	Max %ED %	Allowable Input Power kW	Rated Output Torque N·m	Allowable Radial Load N	Max %ED %	Allowable Input Power kW	Rated Output Torque N·m	Allowable Radial Load N	Max %ED %		
4A105	21	3.04	563	22003	100	3.18	394	20067	100	3.18	336	19400	100	3600	580
	22	-	-	-	-	-	-	-	-	-	-	-	-	-	-
	25	-	-	-	-	-	-	-	-	-	-	-	-	-	-
	28	2.82	698	23570	100	3.18	526	21367	100	3.18	448	20700	100	3600	938
	35	2.89	898	21886	100	3.18	661	22367	100	3.18	563	21700	100	3600	955
	39	2.89	982	20608	100	3.18	722	22767	100	3.18	616	22100	100	3600	1050
	46	2.54	1020	20100	100	3.18	854	22300	100	3.18	728	22800	100	3600	1020
	53	2.2	1020	20100	100	3.18	982	20533	100	3.18	840	22700	100	3600	1020
	60	1.95	1020	20100	100	2.46	862	22300	100	2.46	735	23800	100	3600	1020
	67	1.57	932	21400	100	2.29	908	21717	100	2.34	790	23300	100	3600	932
	74	1.57	1020	20100	100	2.29	994	20483	100	2.34	864	22400	100	3600	1020
	80	1.33	932	21400	100	1.67	790	23233	100	1.67	673	24400	100	3600	932
	88	1.33	1020	20100	100	1.67	864	22300	100	1.67	736	23800	100	3600	1020
	102	1.14	1020	20100	100	1.59	952	21083	100	1.59	812	23000	100	3600	1020
	112	0.94	932	21400	100	1.2	792	23233	100	1.2	675	24400	100	3600	932
	123	0.94	1020	20100	100	1.2	866	22300	100	1.2	738	23800	100	3600	1020
	151	0.77	1020	20100	100	1.08	964	20900	100	1.08	822	22900	100	3600	1020
	179	0.64	1003	20319	100	0.78	817	22867	100	0.78	697	24200	100	3600	1010
207	0.54	979	20676	100	0.69	834	22717	100	0.71	736	23800	100	3600	1010	
249	0.41	891	21976	100	0.52	753	23700	100	0.56	702	24200	100	3600	897	
305	0.38	1016	20165	100	0.51	919	21633	100	0.57	866	22300	100	3600	1020	

Notes: [1] For selections noted with \*, the duty cycle for units mounted in the Y2 configuration is limited to 75% (10 minute cycle time).

# Rating Tables



# Rating Tables

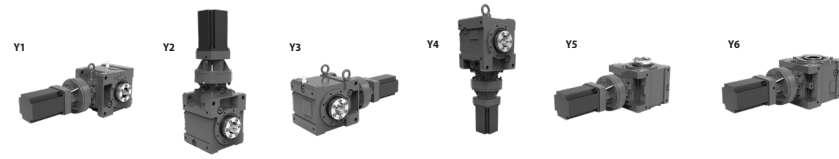
Size	Ratio	Input Speed												Allowable Max Input Speed r/min	Allowable Peak Torque at Startup and Stop N·m
		2000 r/min				2500 r/min				3000 r/min					
		Allowable Input Power kW	Rated Output Torque N·m	Allowable Radial Load N	Max %ED	Allowable Input Power kW	Rated Output Torque N·m	Allowable Radial Load N	Max %ED	Allowable Input Power kW	Rated Output Torque N·m	Allowable Radial Load N	Max %ED		
4A105	21	3.18	302	18767	100	3.18	235	17500	100	3.18	196	16800	100	3600	580
	22	-	-	-	-	-	-	-	-	-	-	-	-	-	-
	25	-	-	-	-	-	-	-	-	-	-	-	-	-	-
	28	3.18	403	20033	100	3.18	314	18700	100	3.18	261	18000	100	3600	938
	35	3.18	507	21033	100	3.18	394	19700	100	3.18	329	19000	100	3600	955
	39	3.18	554	21433	100	3.18	431	20100	100	3.18	359	19300	100	3600	1050
	46	3.18	655	22100	100	3.18	510	20700	100	3.18	425	20000	100	3600	1020
	53	3.18	756	22233	100	3.18	588	21300	100	3.18	490	20600	100	3600	1020
	60	2.46	662	23433	100	2.46	516	22700	100	2.46	430	21900	100	3600	1020
	67	2.34	711	23367	100	2.34	554	23500	100	2.34	462	22600	100	3600	932
	74	2.34	778	22867	100	2.34	606	23800	100	2.34	505	23000	100	3600	1020
	80	1.67	606	24767	100	1.67	471	25500	100	1.67	392	24400	100	3600	932
	88	1.67	662	24433	100	1.67	515	25700	100	1.67	429	24900	100	3600	1020
	102	1.59	731	23767	100	1.59	568	25300	100	1.59	474	25900	100	3600	1020
	112	1.2	608	24933	100	1.2	473	26000	100	1.2	394	26400	100	3600	932
	123	1.2	665	24433	100	1.2	518	25700	100	1.2	431	26200	100	3600	1020
	151	1.08	739	23700	100	1.08	572	25300	100	1.08	477	25900	100	3600	1020
	179	0.78	627	24767	100	0.78	488	25900	100	0.78	407	26300	100	3600	1010
207	0.71	662	24433	100	0.71	515	25700	100	0.71	429	26200	100	3600	1010	
249	0.57	637	24700	100	0.58	508	25700	100	0.58	423	26300	100	3600	897	
305	0.57	779	23200	100	0.57	606	25000	100	0.57	505	25800	100	3600	1020	

Size	Ratio	Input Speed				Allowable Max Input Speed r/min	Allowable Peak Torque at Startup and Stop N·m
		3600 r/min					
		Allowable Input Power kW	Rated Output Torque N·m	Allowable Radial Load N	Max %ED		
4A100	21	2.49	128	16300	100	3600	580
	22	-	-	-	-	-	-
	25	-	-	-	-	-	-
	28	3.18	218	17200	100	3600	849
	35	3.18	274	18200	100	3600	776
	39	3.18	299	18600	100	3600	849
	46	3.18	354	19300	100	3600	849
	53	3.18	408	19900	100	3600	849
	60	2.46	358	21000	100	3600	849
	67	2.34	385	21800	100	3600	776
	74	2.34	421	22200	100	3600	849
	80	1.67	327	23400	100	3600	776
	88	1.67	357	23900	100	3600	849
	102	1.59	395	24900	100	3600	849
	112	1.2	329	26100	100	3600	776
	123	1.2	360	26600	100	3600	849
	151	1.08	398	26400	100	3600	849
	179	0.78	339	26700	100	3600	849
207	0.71	358	26600	100	3600	849	
249	0.58	353	26600	100	3600	849	
305	0.57	421	26300	100	3600	849	

Notes: [1] For selections noted with \*, the duty cycle for units mounted in the Y2 configuration is limited to 75% (10 minute cycle time).

# Rating Tables

# Rating Tables



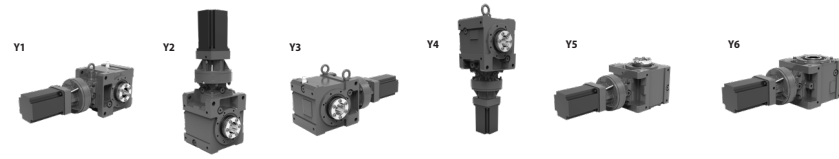
Size	Ratio	Input Speed												Allowable Max Input Speed r/min	Allowable Peak Torque at Startup and Stop N·m
		1000 r/min				1500 r/min				1750 r/min					
		Allowable Input Power kW	Rated Output Torque N·m	Allowable Radial Load N	Max %ED	Allowable Input Power kW	Rated Output Torque N·m	Allowable Radial Load N	Max %ED	Allowable Input Power kW	Rated Output Torque N·m	Allowable Radial Load N	Max %ED		
4A110	21	3.49	647	21614	100	3.55	440	19867	100	3.55	375	19200	100	3600	657
	22	-	-	-	-	-	-	-	-	-	-	-	-	-	-
	25	-	-	-	-	-	-	-	-	-	-	-	-	-	-
	28	3.55	878	22011	100	3.55	586	21067	100	3.55	500	20400	100	3600	1220
	35	3.54	1101	18524	100	3.55	737	21967	100	3.55	629	21300	100	3600	1120
	39	3.54	1199	16232	100	3.55	806	22283	100	3.55	688	21700	100	3600	1220
	46	3.05	1220	15811	100	3.55	953	20967	100	3.55	813	22300	100	3600	1220
	53	2.64	1220	15800	100	3.55	1098	18467	100	3.55	938	21300	100	3600	1220
	60	2.34	1220	15800	100	3.18	1117	18183	100	3.18	951	21100	100	3600	1220
	67	1.89	1120	18200	100	2.72	1079	18850	100	2.72	921	21600	100	3600	1120
	74	1.89	1220	15800	100	2.72	1185	16717	100	2.72	1010	20300	100	3600	1220
	80	1.59	1120	18200	100	1.91	903	21833	100	1.91	770	23500	100	3600	1120
	88	1.59	1220	15800	100	1.91	990	20517	100	1.91	842	22600	100	3600	1220
	102	1.37	1220	15800	100	1.9	1137	17633	100	1.9	972	20800	100	3600	1220
	112	1.13	1120	18200	100	1.5	991	20433	100	1.5	847	22600	100	3600	1120
	123	1.13	1220	15800	100	1.5	1088	18750	100	1.5	926	21500	100	3600	1220
	151	0.92	1220	15800	100	1.3	1156	17350	100	1.3	984	20600	100	3600	1220
	179	0.78	1220	15800	100	0.94	991	20433	100	0.94	847	22600	100	3600	1220
207	0.67	1220	15800	100	0.86	1049	19500	100	0.86	893	22000	100	3600	1220	
249	0.56	1220	15800	100	0.67	981	20617	100	0.67	836	22700	100	3600	1220	
305	0.46	1220	15800	100	0.66	1185	16533	100	0.66	1010	20200	100	3600	1220	

Size	Ratio	Input Speed												Allowable Max Input Speed r/min	Allowable Peak Torque at Startup and Stop N·m
		2000 r/min				2500 r/min				3000 r/min					
		Allowable Input Power kW	Rated Output Torque N·m	Allowable Radial Load N	Max %ED	Allowable Input Power kW	Rated Output Torque N·m	Allowable Radial Load N	Max %ED	Allowable Input Power kW	Rated Output Torque N·m	Allowable Radial Load N	Max %ED		
4A110	21	3.55	338	18600	100	3.55	263	17400	100	3.55	219	16600	100	3600	657
	22	-	-	-	-	-	-	-	-	-	-	-	-	-	-
	25	-	-	-	-	-	-	-	-	-	-	-	-	-	-
	28	3.55	450	19767	100	3.55	350	18500	100	3.55	292	17800	100	3600	1220
	35	3.55	566	20667	100	3.55	440	19400	100	3.55	367	18700	100	3600	1120
	39	3.55	619	21067	100	3.55	481	19800	100	3.55	401	19100	100	3600	1220
	46	3.55	732	21667	100	3.55	569	20400	100	3.55	474	19700	100	3600	1220
	53	3.55	844	21167	100	3.55	656	20900	100	3.55	547	20200	100	3600	1220
	60	3.18	856	21333	100	3.18	666	21800	100	3.18	555	21100	100	3600	1220
	67	2.72	829	22033	100	2.72	644	22900	100	2.72	536	22200	100	3600	1120
	74	2.72	908	21267	100	2.72	704	23200	100	2.72	587	22500	100	3600	1220
	80	1.91	693	24000	100	1.91	538	25000	100	1.91	448	24100	100	3600	1120
	88	1.91	758	23467	100	1.91	589	25200	100	1.91	491	24500	100	3600	1220
	102	1.9	874	22000	100	1.9	679	24400	100	1.9	566	25300	100	3600	1220
	112	1.5	762	23433	100	1.5	592	25100	100	1.5	493	25800	100	3600	1120
	123	1.5	833	22567	100	1.5	647	24700	100	1.5	539	25500	100	3600	1220
	151	1.3	886	21833	100	1.3	689	24300	100	1.3	574	25300	100	3600	1220
	179	0.94	762	23433	100	0.94	593	25100	100	0.94	495	25800	100	3600	1220
207	0.86	804	22967	100	0.86	625	24900	100	0.86	521	25700	100	3600	1220	
249	0.67	753	23533	100	0.67	586	25200	100	0.67	488	25900	100	3600	1220	
305	0.66	910	21500	100	0.66	709	24100	100	0.66	591	25100	100	3600	1220	

Notes: [1] For selections noted with \*, the duty cycle for units mounted in the Y2 configuration is limited to 75% (10 minute cycle time).

# Rating Tables

# Rating Tables



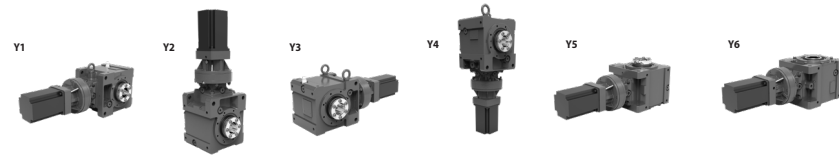
Size	Ratio	Input Speed				Allowable Max Input Speed r/min	Allowable Peak Torque at Startup and Stop N·m
		3600 r/min					
		Allowable Input Power kW	Rated Output Torque N·m	Allowable Radial Load N	Max %ED %		
4A110	21	3.55	182	15900	100	3600	657
	22	-	-	-	-	-	-
	25	-	-	-	-	-	-
	28	3.55	243	17100	100	3600	1220
	35	3.55	306	18000	100	3600	1120
	39	3.55	334	18300	100	3600	1220
	46	3.55	395	19000	100	3600	1220
	53	3.55	456	19500	100	3600	1220
	60	3.18	463	20400	100	3600	1220
	67	2.72	447	21400	100	3600	1120
	74	2.72	489	21700	100	3600	1220
	80	1.91	374	23100	100	3600	1120
	88	1.91	409	23600	100	3600	1220
	102	1.9	472	24400	100	3600	1220
	112	1.5	411	25600	100	3600	1120
	123	1.5	449	26100	100	3600	1220
	151	1.3	479	25900	100	3600	1220
	179	0.94	412	26300	100	3600	1220
207	0.86	434	26200	100	3600	1220	
249	0.67	407	26300	100	3600	1220	
305	0.66	492	25800	100	3600	1220	

Size	Ratio	Input Speed												Allowable Max Input Speed r/min	Allowable Peak Torque at Startup and Stop N·m
		1000 r/min				1500 r/min				1750 r/min					
		Allowable Input Power kW	Rated Output Torque N·m	Allowable Radial Load N	Max %ED %	Allowable Input Power kW	Rated Output Torque N·m	Allowable Radial Load N	Max %ED %	Allowable Input Power kW	Rated Output Torque N·m	Allowable Radial Load N	Max %ED %		
4A115	21	3.53	653	21581	100	3.92	486	19583	100	3.92	414	19000	100	3600	657
	22	-	-	-	-	-	-	-	-	-	-	-	-	-	-
	25	-	-	-	-	-	-	-	-	-	-	-	-	-	-
	28	3.92	969	20708	100	3.92	647	20767	100	3.92	552	20100	100	3600	1290
	35	3.92	1218	15854	100	3.92	814	21500	100	3.92	694	21000	100	3600	1290
	39	3.75	1274	14311	100	3.92	890	21550	100	3.92	759	21300	100	3600	1290
	46	3.22	1290	13900	100	3.9	1049	19483	100	3.9	893	21900	100	3600	1290
	53	2.79	1290	13900	100	3.9	1205	16067	100	3.9	1030	19900	100	3600	1290
	60	2.46	1290	13900	100	3.57	1253	14783	100	3.57	1070	19200	100	3600	1290
	67	2.18	1290	13900	100	3.11	1233	15333	100	3.11	1050	19500	100	3600	1290
	74	1.99	1290	13900	100	2.89	1253	14783	100	2.89	1070	19200	100	3600	1290
	80	1.83	1290	13900	100	2.22	1049	19500	100	2.22	894	22000	100	3600	1290
	88	1.67	1290	13900	100	2.22	1146	17450	100	2.22	978	20700	100	3600	1290
	102	1.44	1290	13900	100	2.09	1253	14783	100	2.09	1070	19200	100	3600	1290
	112	1.31	1290	13900	100	1.81	1195	16350	100	1.81	1020	20100	100	3600	1290
	123	1.19	1290	13900	100	1.73	1253	14783	100	1.73	1070	19200	100	3600	1290
	151	0.97	1290	13900	100	1.41	1253	14783	100	1.41	1070	19200	100	3600	1290
	179	0.82	1290	13900	100	1.11	1166	16983	100	1.11	998	20400	100	3600	1290
207	0.71	1290	13900	100	1.01	1233	15417	100	1.01	1050	19500	100	3600	1290	
249	0.59	1290	13900	100	0.76	1108	18283	100	0.76	947	21200	100	3600	1290	
305	0.48	1290	13900	100	0.7	1253	14783	100	0.7	1070	19200	100	3600	1290	

Notes: [1] For selections noted with \*, the duty cycle for units mounted in the Y2 configuration is limited to 75% Equivalent Duty (10 minute cycle time).

# Rating Tables

# Rating Tables



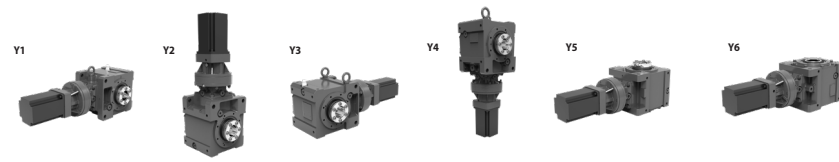
Size	Ratio	Input Speed												Allowable Max Input Speed r/min	Allowable Peak Torque at Startup and Stop N·m
		2000 r/min				2500 r/min				3000 r/min					
		Allowable Input Power kW	Rated Output Torque N·m	Allowable Radial Load N	Max %ED	Allowable Input Power kW	Rated Output Torque N·m	Allowable Radial Load N	Max %ED	Allowable Input Power kW	Rated Output Torque N·m	Allowable Radial Load N	Max %ED		
4A115	21	3.92	373	18400	100	3.92	290	17200	100	3.92	242	16500	100	3600	657
	22	-	-	-	-	-	-	-	-	-	-	-	-	-	-
	25	-	-	-	-	-	-	-	-	-	-	-	-	-	-
	28	3.92	497	19500	100	3.92	387	18300	100	3.92	322	17600	100	3600	1290
	35	3.92	625	20400	100	3.92	486	19200	100	3.92	405	18500	100	3600	1290
	39	3.92	683	20667	100	3.92	532	19400	100	3.92	443	18800	100	3600	1290
	46	3.9	804	21267	100	3.9	625	20000	100	3.9	521	19400	100	3600	1290
	53	3.9	927	20067	100	3.9	721	20400	100	3.9	601	19900	100	3600	1290
	60	3.57	963	19867	100	3.57	748	21200	100	3.57	623	20600	100	3600	1290
	67	3.11	945	20433	100	3.11	736	22300	100	3.11	613	21700	100	3600	1290
	74	2.89	963	20433	100	2.89	748	22900	100	2.89	623	22300	100	3600	1290
	80	2.22	805	22833	100	2.22	626	24500	100	2.22	521	23600	100	3600	1290
	88	2.22	880	21900	100	2.22	684	24300	100	2.22	570	24000	100	3600	1290
	102	2.09	962	20700	100	2.09	747	23700	100	2.09	623	24900	100	3600	1290
	112	1.81	918	21433	100	1.81	714	24100	100	1.81	595	25100	100	3600	1290
	123	1.73	962	20700	100	1.73	746	23700	100	1.73	622	24900	100	3600	1290
	151	1.41	962	20700	100	1.41	747	23700	100	1.41	623	24900	100	3600	1290
	179	1.11	898	21667	100	1.11	698	24200	100	1.11	582	25200	100	3600	1290
207	1.01	945	20933	100	1.01	735	23800	100	1.01	612	25000	100	3600	1290	
249	0.76	852	22300	100	0.76	663	24500	100	0.76	553	25400	100	3600	1290	
305	0.7	963	20700	100	0.7	749	23700	100	0.7	624	24900	100	3600	1290	

Size	Ratio	Input Speed				Allowable Max Input Speed r/min	Allowable Peak Torque at Startup and Stop N·m
		3600 r/min					
		Allowable Input Power kW	Rated Output Torque N·m	Allowable Radial Load N	Max %ED		
4A115	21	3.7	190	15900	100	3600	657
	22	-	-	-	-	-	-
	25	-	-	-	-	-	-
	28	3.92	268	16900	100	3600	1290
	35	3.92	337	17800	100	3600	1290
	39	3.92	369	18100	100	3600	1290
	46	3.9	434	18700	100	3600	1290
	53	3.9	501	19300	100	3600	1290
	60	3.57	520	20000	100	3600	1290
	67	3.11	511	21000	100	3600	1290
	74	2.89	520	21500	100	3600	1290
	80	2.22	434	22700	100	3600	1290
	88	2.22	475	23100	100	3600	1290
	102	2.09	519	24100	100	3600	1290
	112	1.81	496	25100	100	3600	1290
	123	1.73	518	25700	100	3600	1290
	151	1.41	519	25700	100	3600	1290
	179	1.11	485	25900	100	3600	1290
207	1.01	510	25700	100	3600	1290	
249	0.76	461	26000	100	3600	1290	
305	0.7	520	25700	100	3600	1290	

Notes: [1] For selections noted with \*, the duty cycle for units mounted in the Y2 configuration is limited to 75% Equivalent Duty (10 minute cycle time).

# Rating Tables

# Rating Tables



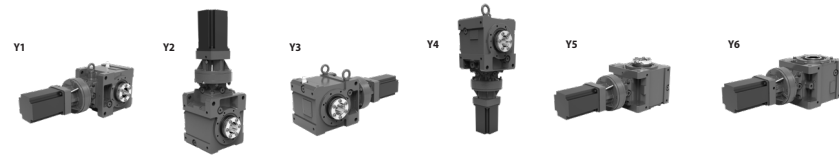
Size	Ratio	Input Speed												Allowable Max Input Speed r/min	Allowable Peak Torque at Startup and Stop N·m
		1000 r/min				1500 r/min				1750 r/min					
		Allowable Input Power kW	Rated Output Torque N·m	Allowable Radial Load N	Max %ED	Allowable Input Power kW	Rated Output Torque N·m	Allowable Radial Load N	Max %ED	Allowable Input Power kW	Rated Output Torque N·m	Allowable Radial Load N	Max %ED		
4A120	21	6.42	1192	16427	100	6.54	810	17833	100	6.54	691	17500	100	3600	1240
	22	6.01	1190	16616	100	6.54	865	17933	100	6.54	737	17600	100	3600	1290
	25	5.93	1281	14138	100	6.54	945	18133	100	6.54	806	17800	100	3600	1290
	28	5.23	1290	13900	100	6.54	1079	18267	100	6.54	921	18100	100	3600	1290
	35	4.16	1290	13900	100	5.07	1050	19067	100	5.07	898	19900	100	3600	1290
	39	3.81	1290	13900	100	5.07	1155	17267	100	5.07	982	20100	100	3600	1290
	46	3.22	1290	13900	100	4.67	1253	14783	100	4.67	1070	19200	100	3600	1290
	53	2.79	1290	13900	100	4.05	1253	14783	100	4.05	1070	19200	100	3600	1290
	60	2.46	1290	13900	100	3.57	1253	14783	100	3.57	1070	19200	100	3600	1290
	67	2.18	1290	13900	100	3.16	1253	14783	100	3.16	1070	19200	100	3600	1290
	74	1.99	1290	13900	100	2.89	1253	14783	100	2.89	1070	19200	100	3600	1290
	80	1.83	1290	13900	100	2.66	1253	14783	100	2.66	1070	19200	100	3600	1290
	88	1.67	1290	13900	100	2.43	1253	14783	100	2.43	1070	19200	100	3600	1290
	102	1.44	1290	13900	100	2.09	1253	14783	100	2.09	1070	19200	100	3600	1290
	112	1.31	1290	13900	100	1.9	1253	14783	100	1.9	1070	19200	100	3600	1290
	123	1.19	1290	13900	100	1.73	1253	14783	100	1.73	1070	19200	100	3600	1290
	151	0.97	1290	13900	100	1.41	1253	14783	100	1.41	1070	19200	100	3600	1290
	179	0.82	1290	13900	100	1.19	1253	14783	100	1.19	1070	19200	100	3600	1290
207	0.71	1290	13900	100	1.03	1253	14783	100	1.03	1070	19200	100	3600	1290	
249	0.59	1290	13900	100	0.86	1253	14783	100	0.86	1070	19200	100	3600	1290	
305	0.48	1290	13900	100	0.7	1253	14783	100	0.7	1070	19200	100	3600	1290	

Size	Ratio	Input Speed												Allowable Max Input Speed r/min	Allowable Peak Torque at Startup and Stop N·m
		2000 r/min				2500 r/min				3000 r/min					
		Allowable Input Power kW	Rated Output Torque N·m	Allowable Radial Load N	Max %ED	Allowable Input Power kW	Rated Output Torque N·m	Allowable Radial Load N	Max %ED	Allowable Input Power kW	Rated Output Torque N·m	Allowable Radial Load N	Max %ED		
4A120	21	6.54	622	16967	100	6.54	484	15900	50	4.79	295	16100	50	3600	1240
	22	6.54	663	17100	100	6.54	516	16100	50	4.79	315	16400	50	3600	1290
	25	6.54	725	17300	100	6.54	564	16300	50	4.79	344	16700	50	3600	1290
	28	6.05	781	17933	100	5.07	500	17600	100	5.07	417	17000	100	3600	1290
	35	5.07	808	19367	100	5.07	629	18300	100	5.07	524	17700	100	3600	1290
	39	5.07	884	19533	100	5.07	687	18400	100	5.07	573	17900	100	3600	1290
	46	4.67	963	19200	100	4.67	748	19200	100	4.67	624	18700	100	3600	1290
	53	4.05	963	19567	100	4.05	749	20300	100	4.05	624	19700	100	3600	1290
	60	3.57	963	19867	100	3.57	748	21200	100	3.57	623	20600	100	3600	1290
	67	3.16	963	20233	100	3.16	748	22300	100	3.16	623	21600	100	3600	1290
	74	2.89	963	20433	100	2.89	748	22900	100	2.89	623	22300	100	3600	1290
	80	2.66	963	20700	100	2.66	749	23700	100	2.66	625	23000	100	3600	1290
	88	2.43	963	20700	100	2.43	749	23700	100	2.43	624	23700	100	3600	1290
	102	2.09	962	20700	100	2.09	747	23700	100	2.09	623	24900	100	3600	1290
	112	1.9	963	20700	100	1.9	749	23700	100	1.9	625	24900	100	3600	1290
	123	1.73	962	20700	100	1.73	746	23700	100	1.73	622	24900	100	3600	1290
	151	1.41	962	20700	100	1.41	747	23700	100	1.41	623	24900	100	3600	1290
	179	1.19	963	20700	100	1.19	748	23700	100	1.19	623	24900	100	3600	1290
207	1.03	963	20700	100	1.03	749	23700	100	1.03	624	24900	100	3600	1290	
249	0.86	963	20700	100	0.86	748	23700	100	0.86	624	24900	100	3600	1290	
305	0.7	963	20700	100	0.7	749	23700	100	0.7	624	24900	100	3600	1290	

Notes: [1] For selections noted with \*, the duty cycle for units mounted in the Y2 configuration is limited to 75% Equivalent Duty (10 minute cycle time).

# Rating Tables

# Rating Tables



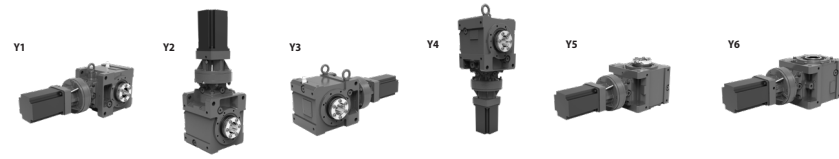
Size	Ratio	Input Speed				Allowable Max Input Speed r/min	Allowable Peak Torque at Startup and Stop N·m
		3600 r/min					
		Allowable Input Power kW	Rated Output Torque N·m	Allowable Radial Load N	Max %ED %		
4A120	21	4.79	246	15500	50	3600	1240
	22	4.79	262	15700	50	3600	1290
	25	4.79	287	16000	50	3600	1290
	28	5.07	347	16400	100	3600	1290
	35	5.07	436	17200	100	3600	1290
	39	5.07	477	17400	100	3600	1290
	46	4.67	520	18200	100	3600	1290
	53	4.05	520	19100	100	3600	1290
	60	3.57	520	20000	100	3600	1290
	67	3.16	519	20900	100	3600	1290
	74	2.89	520	21500	100	3600	1290
	80	2.66	520	22200	100	3600	1290
	88	2.43	520	22900	100	3600	1290
	102	2.09	519	24100	100	3600	1290
	112	1.9	520	24900	100	3600	1290
	123	1.73	518	25700	100	3600	1290
	151	1.41	519	25700	100	3600	1290
	179	1.19	520	25700	100	3600	1290
207	1.03	520	25700	100	3600	1290	
249	0.86	520	25700	100	3600	1290	
305	0.7	520	25700	100	3600	1290	

Size	Ratio	Input Speed												Allowable Max Input Speed r/min	Allowable Peak Torque at Startup and Stop N·m
		1000 r/min				1500 r/min				1750 r/min					
		Allowable Input Power kW	Rated Output Torque N·m	Allowable Radial Load N	Max %ED %	Allowable Input Power kW	Rated Output Torque N·m	Allowable Radial Load N	Max %ED %	Allowable Input Power kW	Rated Output Torque N·m	Allowable Radial Load N	Max %ED %		
4A125	21	6.5	1205	16319	100	7.51	930	17233	100	7.51	793	16900	100	3600	1240
	22	6.04	1195	16519	100	7.51	991	17250	100	7.51	846	17000	100	3600	1290
	25	5.96	1287	14008	100	7.51	1088	17450	100	7.51	925	17200	100	3600	1290
	28	5.23	1290	13900	100	7.51	1243	14817	100	7.51	1060	17400	100	3600	1290
	35	4.16	1290	13900	100	5.92	1233	15333	100	5.92	1050	19000	100	3600	1290
	39	3.81	1290	13900	100	5.52	1253	14783	100	5.52	1070	19200	100	3600	1290
	46	3.22	1290	13900	100	4.67	1253	14783	100	4.67	1070	19200	100	3600	1290
	53	2.79	1290	13900	100	4.05	1253	14783	100	4.05	1070	19200	100	3600	1290
	60	2.46	1290	13900	100	3.57	1253	14783	100	3.57	1070	19200	100	3600	1290
	67	2.18	1290	13900	100	3.16	1253	14783	100	3.16	1070	19200	100	3600	1290
	74	1.99	1290	13900	100	2.89	1253	14783	100	2.89	1070	19200	100	3600	1290
	80	1.83	1290	13900	100	2.66	1253	14783	100	2.66	1070	19200	100	3600	1290
	88	1.67	1290	13900	100	2.43	1253	14783	100	2.43	1070	19200	100	3600	1290
	102	1.44	1290	13900	100	2.09	1253	14783	100	2.09	1070	19200	100	3600	1290
	112	1.31	1290	13900	100	1.9	1253	14783	100	1.9	1070	19200	100	3600	1290
	123	1.19	1290	13900	100	1.73	1253	14783	100	1.73	1070	19200	100	3600	1290
	151	0.97	1290	13900	100	1.41	1253	14783	100	1.41	1070	19200	100	3600	1290
	179	0.82	1290	13900	100	1.19	1253	14783	100	1.19	1070	19200	100	3600	1290
207	0.71	1290	13900	100	1.03	1253	14783	100	1.03	1070	19200	100	3600	1290	
249	0.59	1290	13900	100	0.86	1253	14783	100	0.86	1070	19200	100	3600	1290	
305	0.48	1290	13900	100	0.7	1253	14783	100	0.7	1070	19200	100	3600	1290	

Notes: [1] For selections noted with \*, the duty cycle for units mounted in the Y2 configuration is limited to 75% Equivalent Duty (10 minute cycle time).

# Rating Tables

# Rating Tables



Size	Ratio	Input Speed												Allowable Max Input Speed r/min	Allowable Peak Torque at Startup and Stop N·m
		2000 r/min				2500 r/min				3000 r/min					
		Allowable Input Power kW	Rated Output Torque N·m	Allowable Radial Load N	Max %ED	Allowable Input Power kW	Rated Output Torque N·m	Allowable Radial Load N	Max %ED	Allowable Input Power kW	Rated Output Torque N·m	Allowable Radial Load N	Max %ED		
4A125	21	7.51	714	16433	100	7.51	555	15500	50	5.5	339	15900	50	3600	1240
	22	7.51	761	16567	100	7.51	592	15700	50	5.5	362	16100	50	3600	1290
	25	7.51	833	16733	100	7.51	648	15800	50	5.5	395	16300	50	3600	1290
	28	7.32	935	17067	100	6.95	685	16400	100	6.95	571	16000	100	3600	1290
	35	5.92	945	18533	100	5.92	734	17600	100	5.92	612	17200	100	3600	1290
	39	5.52	963	18800	100	5.52	749	18000	100	5.52	624	17600	100	3600	1290
	46	4.67	963	19200	100	4.67	748	19200	100	4.67	624	18700	100	3600	1290
	53	4.05	963	19567	100	4.05	749	20300	100	4.05	624	19700	100	3600	1290
	60	3.57	963	19867	100	3.57	748	21200	100	3.57	623	20600	100	3600	1290
	67	3.16	963	20233	100	3.16	748	22300	100	3.16	623	21600	100	3600	1290
	74	2.89	963	20433	100	2.89	748	22900	100	2.89	623	22300	100	3600	1290
	80	2.66	963	20700	100	2.66	749	23700	100	2.66	625	23000	100	3600	1290
	88	2.43	963	20700	100	2.43	749	23700	100	2.43	624	23700	100	3600	1290
	102	2.09	962	20700	100	2.09	747	23700	100	2.09	623	24900	100	3600	1290
	112	1.9	963	20700	100	1.9	749	23700	100	1.9	625	24900	100	3600	1290
	123	1.73	962	20700	100	1.73	746	23700	100	1.73	622	24900	100	3600	1290
	151	1.41	962	20700	100	1.41	747	23700	100	1.41	623	24900	100	3600	1290
	179	1.19	963	20700	100	1.19	748	23700	100	1.19	623	24900	100	3600	1290
207	1.03	963	20700	100	1.03	749	23700	100	1.03	624	24900	100	3600	1290	
249	0.86	963	20700	100	0.86	748	23700	100	0.86	624	24900	100	3600	1290	
305	0.7	963	20700	100	0.7	749	23700	100	0.7	624	24900	100	3600	1290	

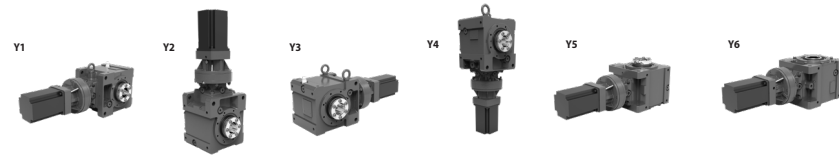
Size	Ratio	Input Speed				Allowable Max Input Speed r/min	Allowable Peak Torque at Startup and Stop N·m
		3600 r/min					
		Allowable Input Power kW	Rated Output Torque N·m	Allowable Radial Load N	Max %ED		
4A125	21	5.5	282	15300	50	3600	1240
	22	5.5	301	15500	50	3600	1290
	25	5.5	330	15800	50	3600	1290
	28	5.92	405	16000	100	3600	1290
	35	5.92	510	16700	100	3600	1290
	39	5.52	520	17100	100	3600	1290
	46	4.67	520	18200	100	3600	1290
	53	4.05	520	19100	100	3600	1290
	60	3.57	520	20000	100	3600	1290
	67	3.16	519	20900	100	3600	1290
	74	2.89	520	21500	100	3600	1290
	80	2.66	520	22200	100	3600	1290
	88	2.43	520	22900	100	3600	1290
	102	2.09	519	24100	100	3600	1290
	112	1.9	520	24900	100	3600	1290
	123	1.73	518	25700	100	3600	1290
	151	1.41	519	25700	100	3600	1290
	179	1.19	520	25700	100	3600	1290
207	1.03	520	25700	100	3600	1290	
249	0.86	520	25700	100	3600	1290	
305	0.7	520	25700	100	3600	1290	

Notes: [1] For selections noted with \*, the duty cycle for units mounted in the Y2 configuration is limited to 75% Equivalent Duty (10 minute cycle time).



# Rating Tables

# Rating Tables



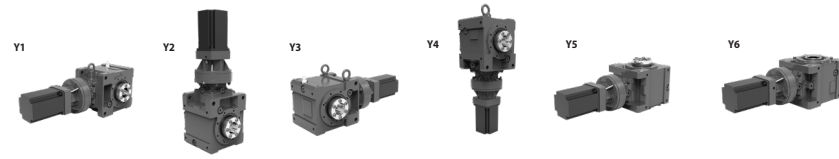
Size	Ratio	Input Speed												Allowable Max Input Speed r/min	Allowable Peak Torque at Startup and Stop N·m
		1000 r/min				1500 r/min				1750 r/min					
		Allowable Input Power kW	Rated Output Torque N·m	Allowable Radial Load N	Max %ED	Allowable Input Power kW	Rated Output Torque N·m	Allowable Radial Load N	Max %ED	Allowable Input Power kW	Rated Output Torque N·m	Allowable Radial Load N	Max %ED		
4B120	21	6.42	1192	28792	100	6.54	810	26533	100	6.54	691	25700	100	3600	1240
	22	6.01	1190	29449	100	6.54	865	26833	100	6.54	737	26000	100	3600	1610
	25	6.01	1299	29949	100	6.54	945	27333	100	6.54	806	26500	100	3600	1760
	28	6.03	1487	30549	100	6.54	1079	28050	100	6.54	921	27300	100	3600	1780
	35	5.07	1573	32792	100	5.07	1050	30500	100	5.07	898	29500	100	3600	1630
	39	5.07	1721	33303	100	5.07	1155	31017	100	5.07	982	30100	100	3600	1780
	46	4.44	1776	35084	100	5.07	1360	32017	100	5.07	1160	31100	100	3600	1780
	53	3.86	1780	36505	100	5.07	1573	32817	100	5.07	1340	31900	100	3600	1780
	60	3.37	1770	36868	100	4.92	1728	33600	100	5.07	1520	32600	100	3600	1770
	67	2.74	1620	38200	100	3.96	1565	35800	100	3.96	1340	34800	100	3600	1620
	74	2.74	1770	36800	100	3.96	1718	36317	100	3.96	1460	35400	100	3600	1770
	80	2.32	1630	38100	100	3.09	1457	38567	100	3.09	1240	37400	100	3600	1630
	88	2.32	1780	36700	100	3.09	1593	38017	100	3.09	1360	38100	100	3600	1780
	102	1.98	1770	36900	100	2.89	1730	37250	100	2.99	1530	39000	100	3600	1770
	112	1.65	1630	38100	100	2.39	1577	38567	100	2.49	1410	39900	100	3600	1630
	123	1.65	1780	36700	100	2.39	1732	37233	100	2.49	1540	38900	100	3600	1780
	151	1.35	1780	36700	100	1.91	1700	37433	100	1.91	1450	39600	100	3600	1780
	179	1.13	1780	36700	100	1.65	1732	37233	100	1.72	1540	38900	100	3600	1780
	207	0.98	1780	36700	100	1.3	1593	38467	100	1.3	1360	40300	100	3600	1780
	249	0.82	1780	36700	100	0.96	1400	39883	100	0.96	1200	41300	100	3600	1780
305	0.67	1780	36700	100	0.94	1700	37517	100	0.94	1450	39600	100	3600	1780	

Size	Ratio	Input Speed												Allowable Max Input Speed r/min	Allowable Peak Torque at Startup and Stop N·m
		2000 r/min				2500 r/min				3000 r/min					
		Allowable Input Power kW	Rated Output Torque N·m	Allowable Radial Load N	Max %ED	Allowable Input Power kW	Rated Output Torque N·m	Allowable Radial Load N	Max %ED	Allowable Input Power kW	Rated Output Torque N·m	Allowable Radial Load N	Max %ED		
4B120	21	6.54	622	24733	100	6.54	484	22800	50	4.79	295	22500	50	3600	1240
	22	6.54	663	25033	100	6.54	516	23100	50	4.79	315	22900	50	3600	1610
	25	6.54	725	25500	100	6.54	564	23500	50	4.79	344	23400	50	3600	1760
	28	6.05	781	26533	100	5.07	500	25000	100	5.07	417	24000	100	3600	1780
	35	5.07	808	28433	100	5.07	629	26300	100	5.07	524	25300	100	3600	1630
	39	5.07	884	28967	100	5.07	687	26700	100	5.07	573	25700	100	3600	1780
	46	5.07	1044	29900	100	5.07	812	27500	100	5.07	677	26600	100	3600	1780
	53	5.07	1206	30667	100	5.07	937	28200	100	5.07	781	27300	100	3600	1780
	60	5.07	1367	31300	100	5.07	1060	28700	100	5.07	885	27900	100	3600	1770
	67	3.96	1206	33500	100	3.96	937	30900	100	3.96	781	29800	100	3600	1620
	74	3.96	1317	34033	100	3.96	1030	31300	100	3.96	854	30300	100	3600	1770
	80	3.09	1117	36000	100	3.09	871	33200	100	3.09	726	32000	100	3600	1630
	88	3.09	1224	36633	100	3.09	952	33700	100	3.09	794	32600	100	3600	1780
	102	2.99	1377	37600	100	2.99	1070	34800	100	2.99	891	33700	100	3600	1770
	112	2.49	1267	38800	100	2.49	982	36600	100	2.49	819	35300	100	3600	1630
	123	2.49	1383	38333	100	2.49	1070	37200	100	2.49	895	35900	100	3600	1780
	151	1.91	1303	39833	100	1.91	1010	40300	100	1.91	844	38900	100	3600	1780
	179	1.72	1387	39900	100	1.72	1080	41900	100	1.72	901	40800	100	3600	1780
	207	1.3	1222	41067	100	1.3	945	42600	100	1.3	788	43300	100	3600	1780
	249	0.96	1079	41900	100	0.96	838	43100	100	0.96	698	43600	100	3600	1780
305	0.94	1303	40500	100	0.94	1010	42300	100	0.94	844	43000	100	3600	1780	

Notes: [1] For selections noted with \*, the duty cycle for units mounted in the Y2 configuration is limited to 75% Equivalent Duty (10 minute cycle time).

# Rating Tables

# Rating Tables



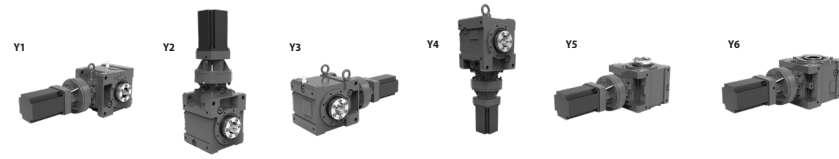
Size	Ratio	Input Speed				Allowable Max Input Speed r/min	Allowable Peak Torque at Startup and Stop N·m
		3600 r/min					
		Allowable Input Power kW	Rated Output Torque N·m	Allowable Radial Load N	Max %ED %		
4B120	21	4.79	246	21500	50	3600	1240
	22	4.79	262	21900	50	3600	1610
	25	4.79	287	22400	50	3600	1760
	28	5.07	347	23000	100	3600	1780
	35	5.07	436	24300	100	3600	1630
	39	5.07	477	24800	100	3600	1780
	46	5.07	564	25700	100	3600	1780
	53	5.07	651	26400	100	3600	1780
	60	5.07	738	27000	100	3600	1770
	67	3.96	651	28800	100	3600	1620
	74	3.96	712	29300	100	3600	1770
	80	3.09	605	30800	100	3600	1630
	88	3.09	661	31400	100	3600	1780
	102	2.99	742	32500	100	3600	1770
	112	2.49	682	34000	100	3600	1630
	123	2.49	746	34600	100	3600	1780
	151	1.91	703	37400	100	3600	1780
	179	1.72	751	39300	100	3600	1780
207	1.3	657	41800	100	3600	1780	
249	0.96	582	43900	100	3600	1780	
305	0.94	703	43500	100	3600	1780	

Size	Ratio	Input Speed												Allowable Max Input Speed r/min	Allowable Peak Torque at Startup and Stop N·m
		1000 r/min				1500 r/min				1750 r/min					
		Allowable Input Power kW	Rated Output Torque N·m	Allowable Radial Load N	Max %ED %	Allowable Input Power kW	Rated Output Torque N·m	Allowable Radial Load N	Max %ED %	Allowable Input Power kW	Rated Output Torque N·m	Allowable Radial Load N	Max %ED %		
4B125	21	6.5	1205	28738	100	7.51	930	26033	100	7.51	793	25200	100	3600	1240
	22	6.04	1195	29427	100	7.51	991	26333	100	7.51	846	25500	100	3600	1610
	25	6.04	1305	29927	100	7.51	1088	26750	100	7.51	925	26000	100	3600	1760
	28	6.06	1494	30527	100	7.51	1243	27367	100	7.51	1060	26700	100	3600	1950
	35	5.26	1632	32516	100	5.92	1233	29733	100	5.92	1050	28900	100	3600	1930
	39	5.26	1782	33005	100	5.92	1342	30233	100	5.92	1150	29400	100	3600	2110
	46	4.75	1902	34595	100	5.92	1593	31050	100	5.92	1360	30300	100	3600	2140
	53	4.63	2140	32600	100	5.92	1835	31667	100	5.92	1560	31000	100	3600	2140
	60	4.08	2140	32600	100	5.66	1982	32567	100	5.66	1690	31900	100	3600	2140
	67	3.31	1960	34900	100	4.81	1908	34333	100	4.88	1650	33500	100	3600	1960
	74	3.31	2140	32600	100	4.81	2085	32833	100	4.88	1810	34000	100	3600	2140
	80	2.78	1960	34900	100	3.96	1865	35400	100	3.96	1590	35900	100	3600	1960
	88	2.78	2140	32600	100	3.96	2040	33667	100	3.96	1740	36500	100	3600	2140
	102	2.4	2140	32600	100	3.52	2103	33033	100	3.77	1920	35200	100	3600	2140
	112	1.98	1960	34900	100	2.93	1932	35183	100	3.18	1790	36600	100	3600	1960
	123	1.98	2140	32600	100	2.93	2110	32967	100	3.18	1960	34800	100	3600	2140
	151	1.61	2140	32600	100	2.35	2083	33250	100	2.38	1800	36500	100	3600	2140
	179	1.36	2140	32600	100	2.02	2125	32800	100	2.28	2050	33800	100	3600	2140
207	1.17	2140	32600	100	1.62	1972	34617	100	1.62	1680	37700	100	3600	2140	
249	0.86	1872	35786	100	1.15	1683	37617	100	1.2	1500	39200	100	3600	2010	
305	0.77	2071	33508	100	1.05	1872	35783	100	1.13	1730	37200	100	3600	2140	

Notes: [1] For selections noted with \*, the duty cycle for units mounted in the Y2 configuration is limited to 75% Equivalent Duty (10 minute cycle time).

# Rating Tables

# Rating Tables



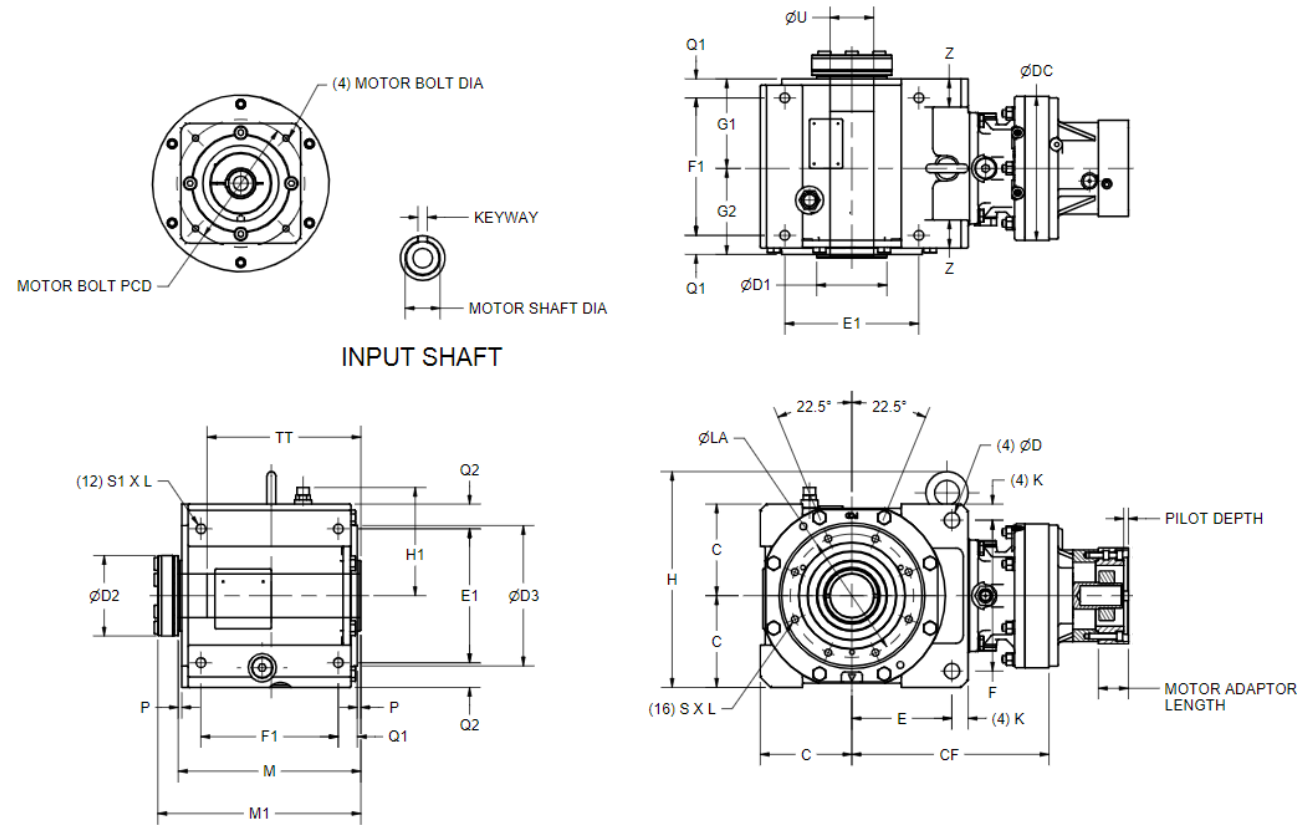
Size	Ratio	Input Speed												Allowable Max Input Speed r/min	Allowable Peak Torque at Startup and Stop N·m
		2000 r/min				2500 r/min				3000 r/min					
		Allowable Input Power kW	Rated Output Torque N·m	Allowable Radial Load N	Max %ED	Allowable Input Power kW	Rated Output Torque N·m	Allowable Radial Load N	Max %ED	Allowable Input Power kW	Rated Output Torque N·m	Allowable Radial Load N	Max %ED		
4B125	21	7.51	714	24267	100	7.51	555	22400	50	5.5	339	22300	50	3600	1240
	22	7.51	761	24567	100	7.51	592	22700	50	5.5	362	22700	50	3600	1610
	25	7.51	833	25000	100	7.51	648	23000	50	5.5	395	23100	50	3600	1760
	28	7.32	935	25767	100	6.95	685	23900	100	6.95	571	23100	100	3600	1950
	35	5.92	945	27800	100	5.92	734	25600	100	5.92	612	24800	100	3600	1930
	39	5.92	1034	28267	100	5.92	803	26000	100	5.92	669	25200	100	3600	2110
	46	5.92	1223	29100	100	5.92	949	26700	100	5.92	791	25900	100	3600	2140
	53	5.92	1403	29767	100	5.92	1090	27300	100	5.92	912	26500	100	3600	2140
	60	5.66	1523	30600	100	5.66	1190	28000	100	5.66	988	27300	100	3600	2140
	67	4.88	1487	32200	100	4.88	1160	29600	100	4.88	963	28800	100	3600	1960
	74	4.88	1627	32600	100	4.88	1260	29800	100	4.88	1050	29100	100	3600	2140
	80	3.96	1433	34533	100	3.96	1120	31800	100	3.96	930	30800	100	3600	1960
	88	3.96	1567	35033	100	3.96	1220	32100	100	3.96	1020	31200	100	3600	2140
	102	3.77	1730	34500	100	3.77	1350	33100	100	3.77	1120	32300	100	3600	2140
	112	3.18	1610	36067	100	3.18	1250	35000	100	3.18	1050	34000	100	3600	1960
	123	3.18	1763	35000	100	3.18	1370	35400	100	3.18	1140	34400	100	3600	2140
	151	2.38	1620	37267	100	2.38	1260	38800	100	2.38	1050	37600	100	3600	2140
	179	2.29	1853	35700	100	2.32	1460	39500	100	2.32	1220	38900	100	3600	2140
207	1.62	1513	38933	100	1.62	1180	41400	100	1.62	982	42400	100	3600	2140	
249	1.2	1350	40167	100	1.2	1050	42100	100	1.2	875	42900	100	3600	2010	
305	1.13	1557	38533	100	1.13	1210	41200	100	1.13	1010	42300	100	3600	2140	

Size	Ratio	Input Speed				Allowable Max Input Speed r/min	Allowable Peak Torque at Startup and Stop N·m
		3600 r/min					
		Allowable Input Power kW	Rated Output Torque N·m	Allowable Radial Load N	Max %ED		
4B125	21	5.5	282	21300	50	3600	1240
	22	5.5	301	21700	50	3600	1610
	25	5.5	330	22100	50	3600	1760
	28	6.95	476	22200	100	3600	1950
	35	5.92	510	23900	100	3600	1930
	39	5.92	557	24300	100	3600	2110
	46	5.92	659	25100	100	3600	2140
	53	5.92	760	25800	100	3600	2140
	60	5.66	824	26500	100	3600	2140
	67	4.88	802	27900	100	3600	1960
	74	4.88	877	28300	100	3600	2140
	80	3.96	775	29800	100	3600	1960
	88	3.96	847	30200	100	3600	2140
	102	3.77	936	31300	100	3600	2140
	112	3.18	871	32900	100	3600	1960
	123	3.18	953	33400	100	3600	2140
	151	2.38	876	36300	100	3600	2140
	179	2.32	1010	37700	100	3600	2140
207	1.62	818	40800	100	3600	2140	
249	1.2	729	43500	100	3600	2010	
305	1.13	842	43000	100	3600	2140	

Notes: [1] For selections noted with \*, the duty cycle for units mounted in the Y2 configuration is limited to 75% Equivalent Duty (10 minute cycle time).

# Dimensions

LHYX-4A100 ▶ 4B125



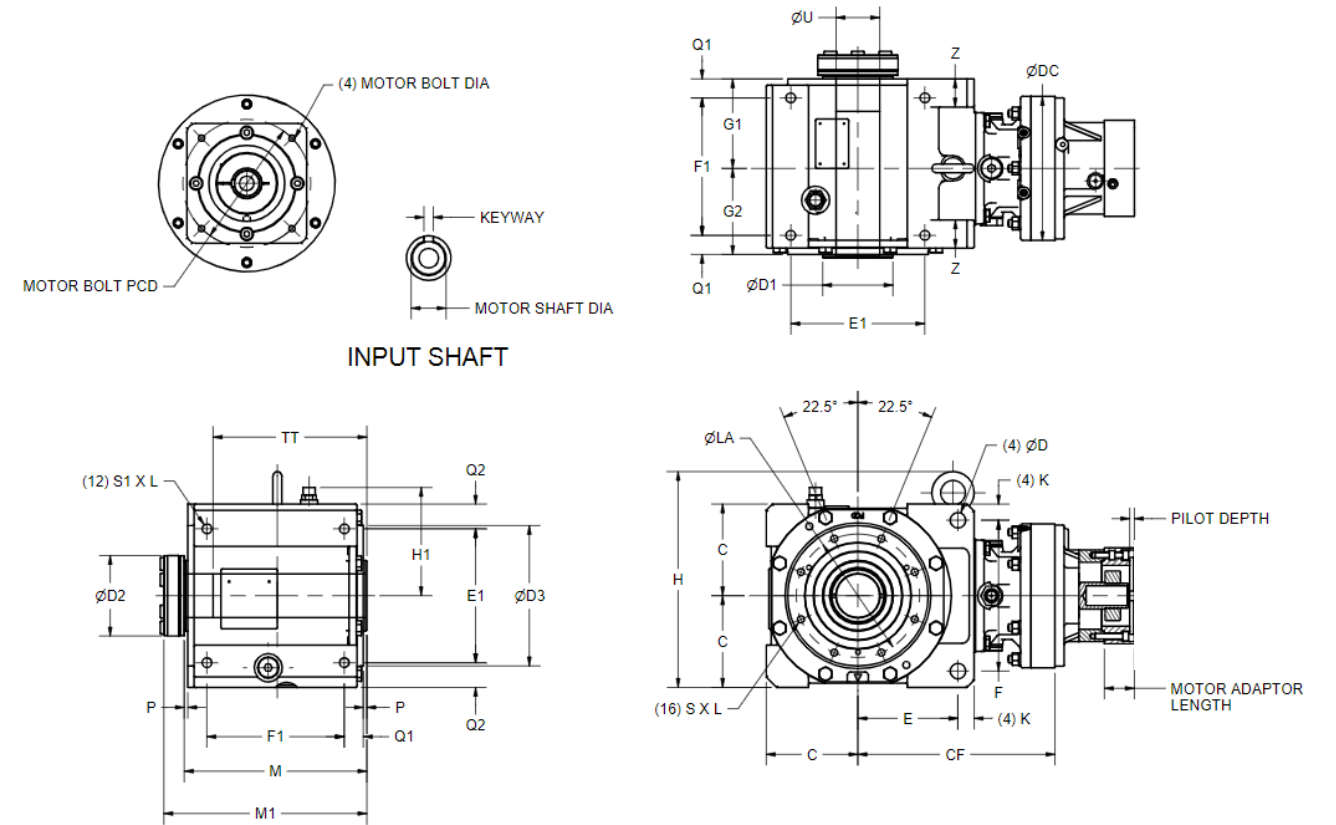
All dimensions are in inches (mm).

Model	C	E	CF	F	K	Z	ØD	E1	F1	Q1
4A100 4A105			9.33 (237)							
4A110 4A115	4.33 (110)	4.49 (114)	9.76 (248)	7.24 (184)	0.71 (18)	1.38 (35)	0.71 (18)	5.91 (150)	6.30 (160)	0.91 (23)
4A120 4A125			9.57 (243)							
4B120 4B125	5.12 (130)	5.59 (142)	11.02 (280)	8.43 (214)	0.91 (23)	1.57 (40)	0.87 (22)	7.48 (190)	7.68 (195)	1.06 (27)

Frame Size	Weight (kg)
4A100, 4A105	53
4A110, 4A115	59
4A120, 4A125	67
4B120, 4B125	96

# Dimensions

LHYX-4A100 ▶ 4B125 cont.



All dimensions are in inches (mm).

Model	G2	H	H1	ØLA	ØD3	S x L	M1	ØD1	ØD2	ØU	
										STD & Max	Min
4A100 4A105											
4A110 4A115	4.33 (110)	10.9 (276)	5.16 (131)	6.10 (155)	6.89 (175)	M10 x 0.67 (M10 x 17)	9.84 (250)	3.35 (85)	4.09 (104)	2-3/16 (55.563)	1-11/16 (42.863)
4A120 4A125											
4B120 4B125	5.00 (127)	12.1 (308)	5.94 (151)	6.89 (175)	7.83 (199)	M12 x 0.79 (M12 x 20)	11.5 (293)	3.94 (100)	4.49 (114)	2-7/16 (61.913)	1-15/16 (49.213)

Frame Size	Weight (kg)
4A100, 4A105	53
4A110, 4A115	59
4A120, 4A125	67
4B120, 4B125	96

# Dimensions

---

Page Intentionally left blank.

---

# 3

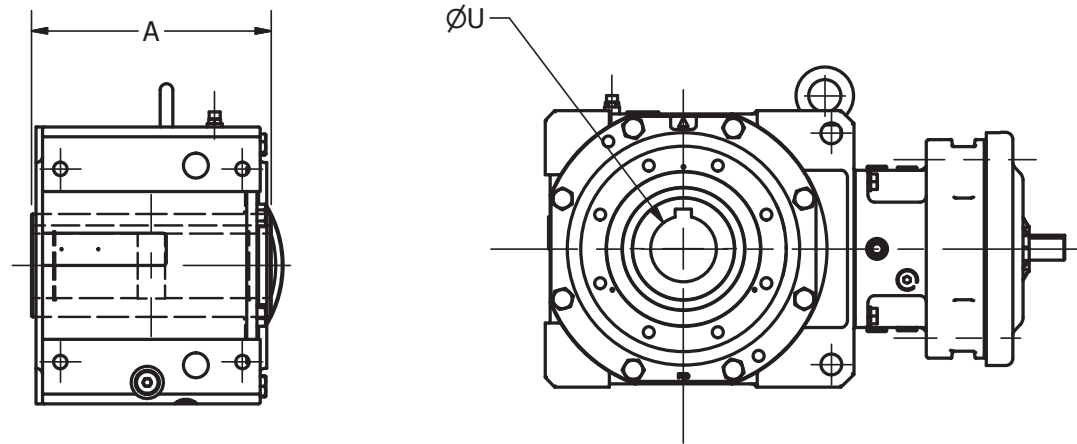
# Options

---

# Keyed Hollow Shaft

# Solid Output Shaft

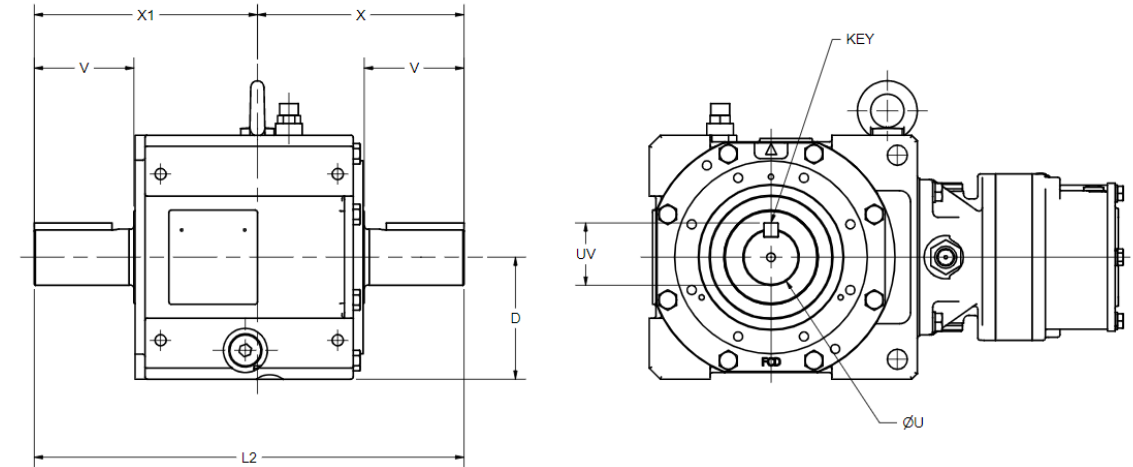
## Keyed Hollow Shaft



All dimensions are in inches (mm).

Frame Size	Standard Inch Bore Dimension			Standard Metric Bore Dimension			A	TK*
	ØU	ØU Tolerance	Keyway	ØU	ØU Tolerance	Keyway		
4A	2.000	+0.0018/+0.0006	1/2 x 1/4	(55)	(+0.046/+0.016)	(16 x 10)	8.50 (216)	6.50 (165)
4B	2.375	+0.0018/+0.0006	5/8 x 5/16	(65)	(+0.046/+0.016)	(18 x 11)	10.20 (259)	7.87 (200)

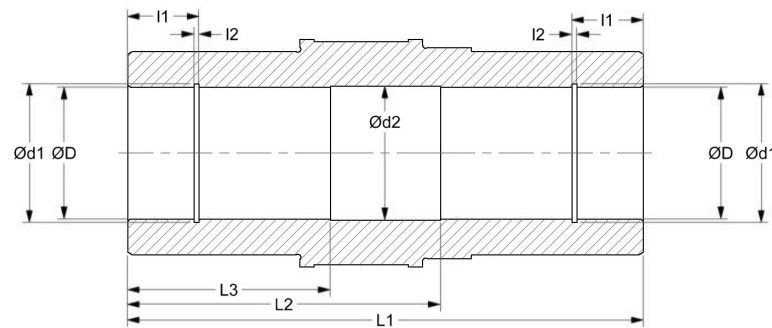
\*Recommended minimum shaft engagement



All dimensions are in inches (mm).

Frame Size	Standard Inch Shaft Dimension			Standard Metric Shaft Dimensions				D	V	X	X1	L2	
	ØU	ØU Tolerance	UV	Key	ØU	ØU Tolerance	UV						Key
4A	2.000	h6: 0/-0.0006	2.22	1/2 x 1/2 x 2.76	(50)	(h6: 0/-0.016)	(53.5)	(14 x 9 x 70)	4.33 (110)	3.54 (90)	7.48 (190)	8.11 (206)	15.59 (396)
4B	2.875	h6: 0/-0.0007	3.20	3/4 x 3/4 x 3.15	(65)	(h6: 0/-0.019)	(69.0)	(18 x 11 x 80)	5.12 (130)	4.53 (115)	9.53 (242)	9.72 (247)	19.25 (489)

# Internal Retaining Ring

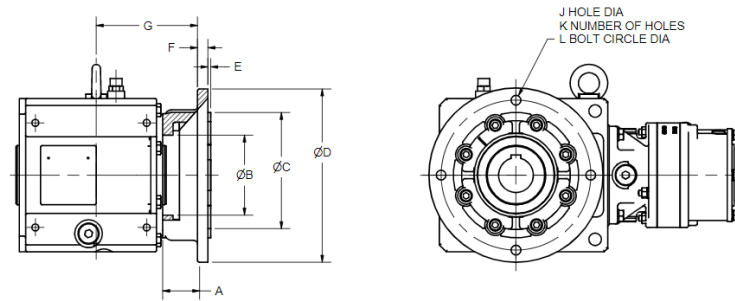


All dimensions are in inches (mm).

Frame Size	BBB		Retaining Ring Groove				Relief	
	ØD	L1	Ød1	I1	I2	Ød2	L2	L3
4A	2 (55)	8.50 (216)	2.09 (58)	1.18 (30)	.069 (2.2)	2.04 (56)	5.16 (131)	3.35 (85)
4B	2-3/8 (65)	10.2 (259)	2.51 (68)	1.18 (30)	0.085 (2.7)	2.42 (66)	6.26 (159)	3.94 (100)

# Output Flange

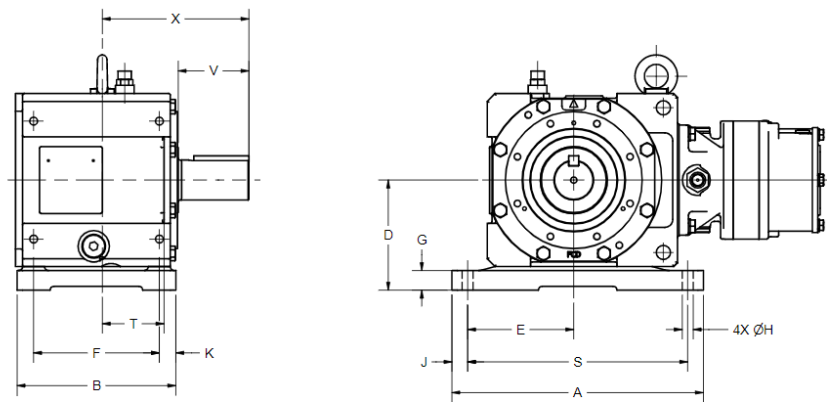
# Shrink Disc



All dimensions are in inches (mm).

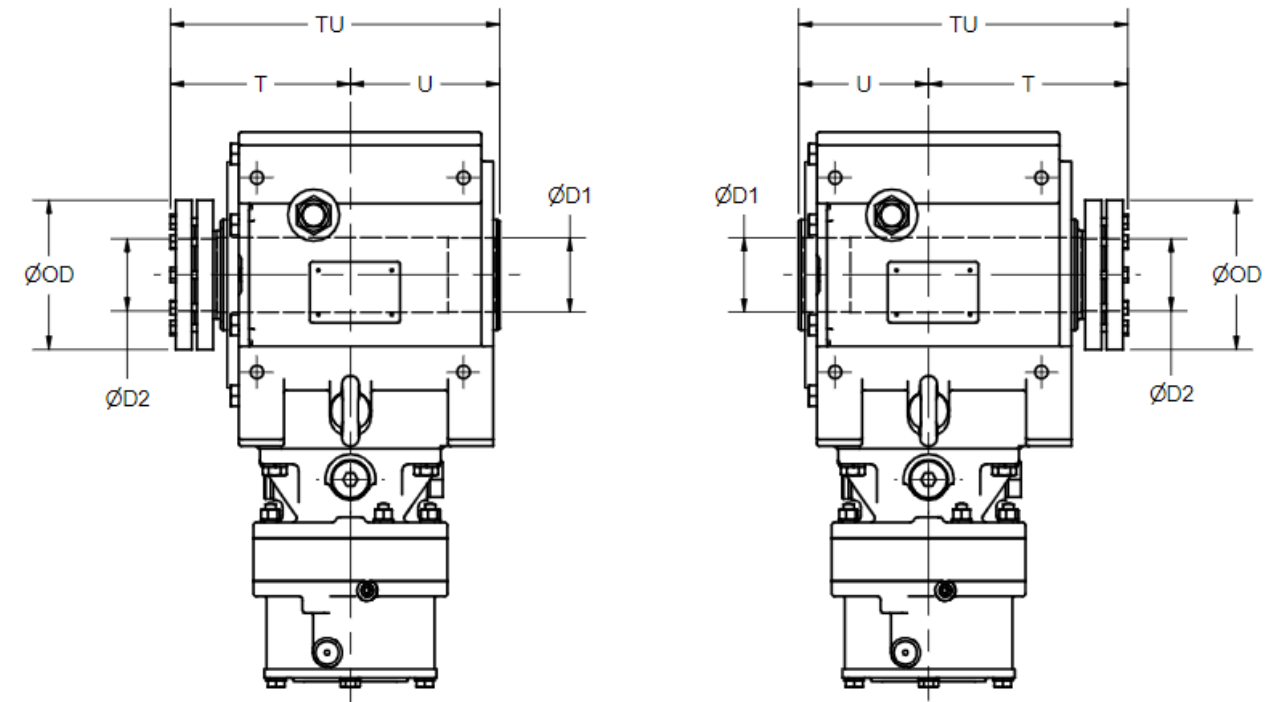
Frame Size	A	ØB	ØC	ØD	E	F	G	J	K	L
4A	2.36 (60)	4.72 (120)	7.09 (180)	9.84 (250)	0.16 (4)	0.59 (15)	6.30 (160)	0.55 (14)	4	8.46 (215)
4B	2.40 (61)	5.51 (140)	9.06 (230)	11.8 (300)	0.16 (4)	0.63 (16)	7.40 (188)	0.55 (14)	4	10.4 (265)

# Foot Mounted



All dimensions are in inches (mm).

Frame Size	A	B	D	E	F	G	ØH	J	K	S	T	V	X
4A	12.6 (320)	7.95 (202)	5.51 (140)	5.31 (135)	6.30 (160)	0.98 (25)	0.55 (14)	0.79 (20)	0.83 (21)	11.0 (280)	2.83 (72)	3.54 (90)	7.48 (190)
4B	15.2 (385)	9.65 (245)	6.69 (170)	6.30 (160)	7.68 (195)	1.38 (35)	0.71 (18)	0.79 (20)	0.98 (25)	13.6 (345)	3.74 (95)	4.53 (115)	9.53 (242)



Left Projecting Shrink Disc

Right Projecting Shrink Disc

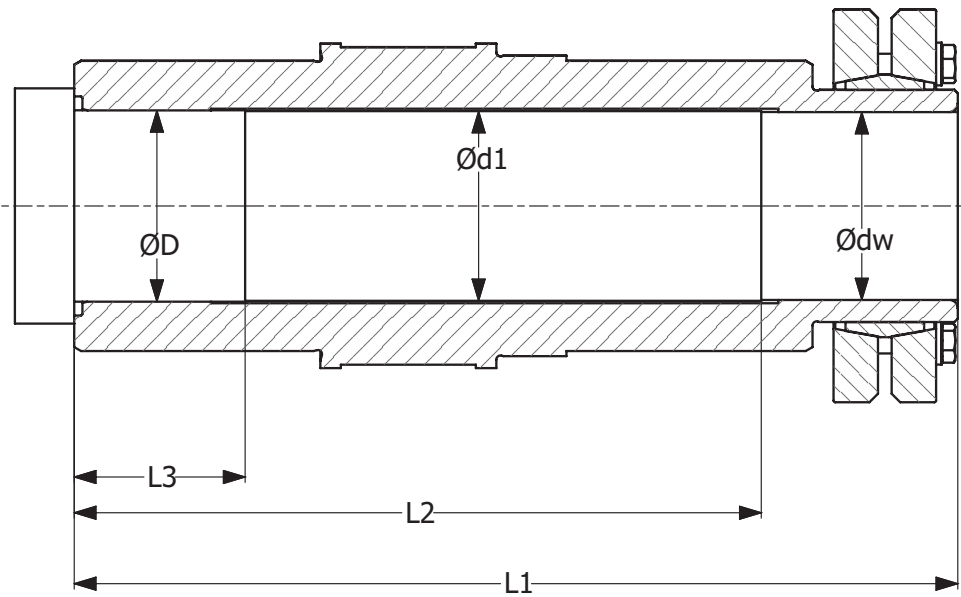
All dimensions are in inches (mm).

Frame Size	ØD1	ØD2	ØOD	TU	Left Projecting Shrink Disc		Right Projecting Shrink Disc	
					T	U	T	U
4A	2.20 (56)	2.17 (55)	4.53 (115)	10.2 (259)	5.28 (134)	4.90 (125)	6.40 (163)	3.78 (96)
4B	2.60 (66)	2.56 (65)	5.71 (145)	12.0 (304)	6.76 (172)	5.19 (132)	6.95 (177)	5.00 (127)



# Shrink Disc

## Recommended Driven Inch Shaft Dimensions



Recommendations for the design of the driven shaft if Shrink Disc connection method is selected:

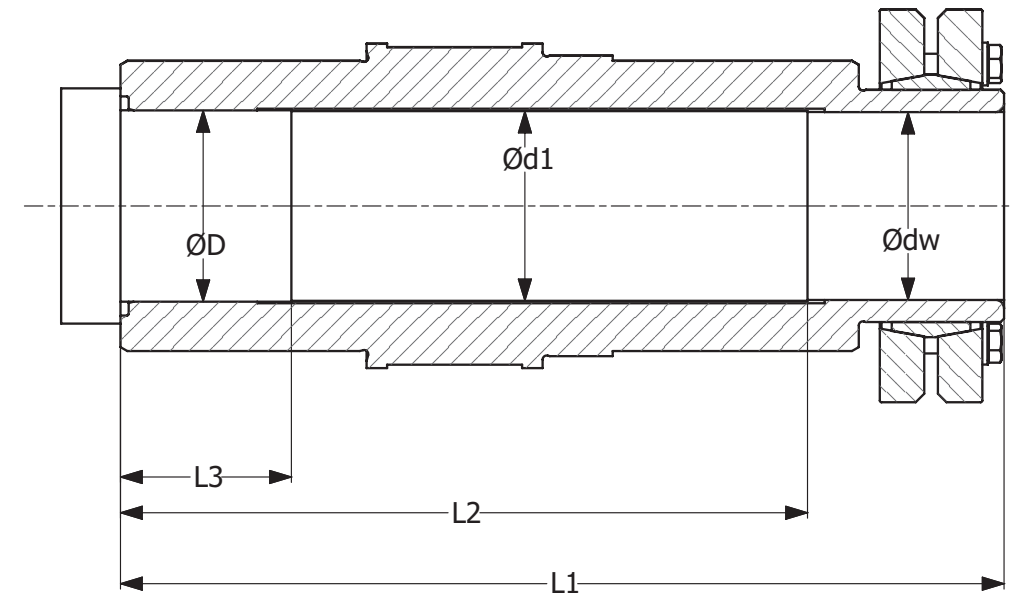
- When ordering the Cyclo® BBB4 with a shrink disc output option, be sure to designate the orientation (left or right) in which to install the shrink disc.
- Once the product is shipped from the Sumitomo factory, the orientation of the shrink disc **cannot** be changed in the field.
- When designing the driven shaft to be inserted into the shrink disc, refer to the table below for shaft design recommendations.

All dimensions are in inches.

Model	Driven Shaft Recommended Dimensions							
	Ødw	Ødw tolerance	Ød1	ØD	ØD tolerance	L1	L2	L3
4A100, 4A105 4A110, 4A115 4A120, 4A125 4A140, 4A145	1-15/16 2 2-3/16	h6: +0/-0.0006 h6: +0/-0.0007 h6: +0/-0.0007	1.91 1.98 2.19	1.98 2.04 2.22	h7: +0/-0.0010 h7: +0/-0.0012 h7: +0/-0.0012	10.18	7.91	1.97
4B120, 4B125 4B140, 4B145 4B160, 4B165	2 2-3/16 2-3/8 2-7/16	h6: +0/-0.0007	1.98 2.19 2.39 2.46	2.04 2.22 2.41 2.48	h7: +0/-0.0012	11.95	9.60	1.97

# Shrink Disc

## Recommended Driven Metric Shaft Dimensions

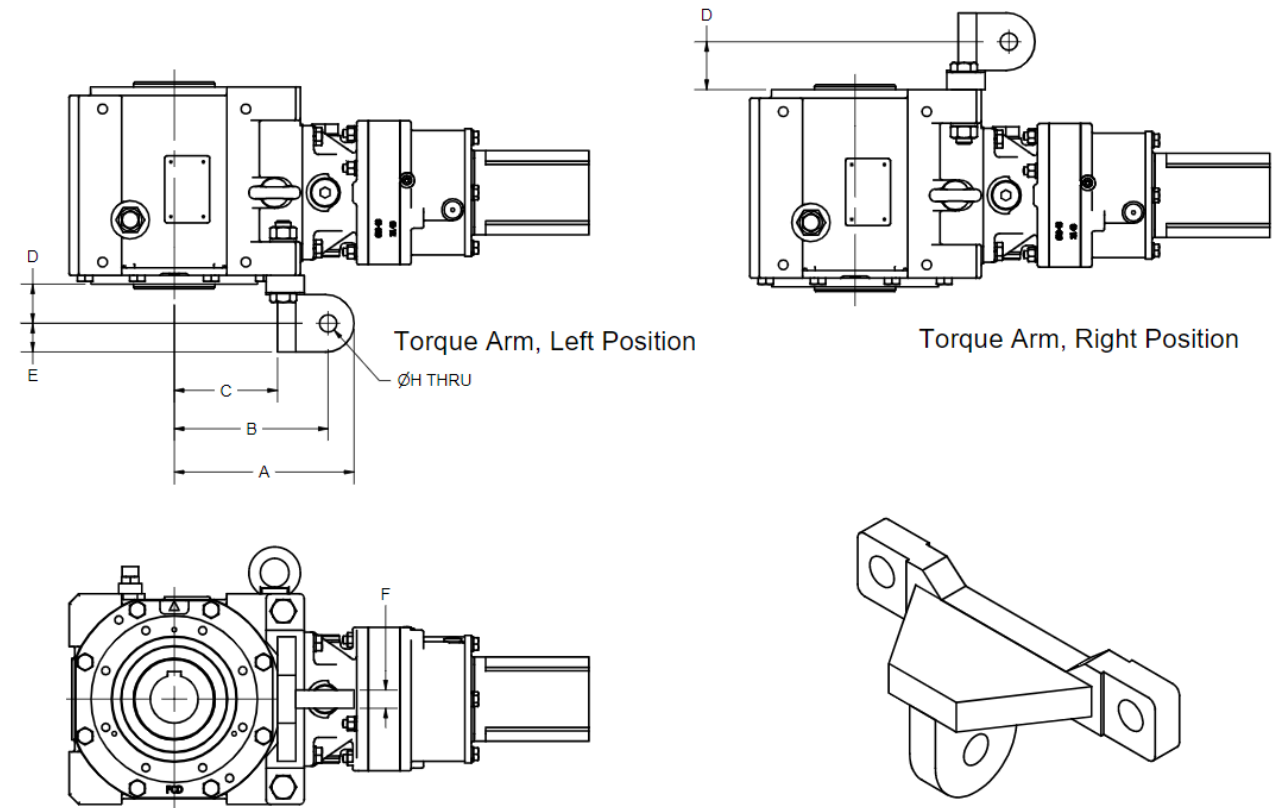
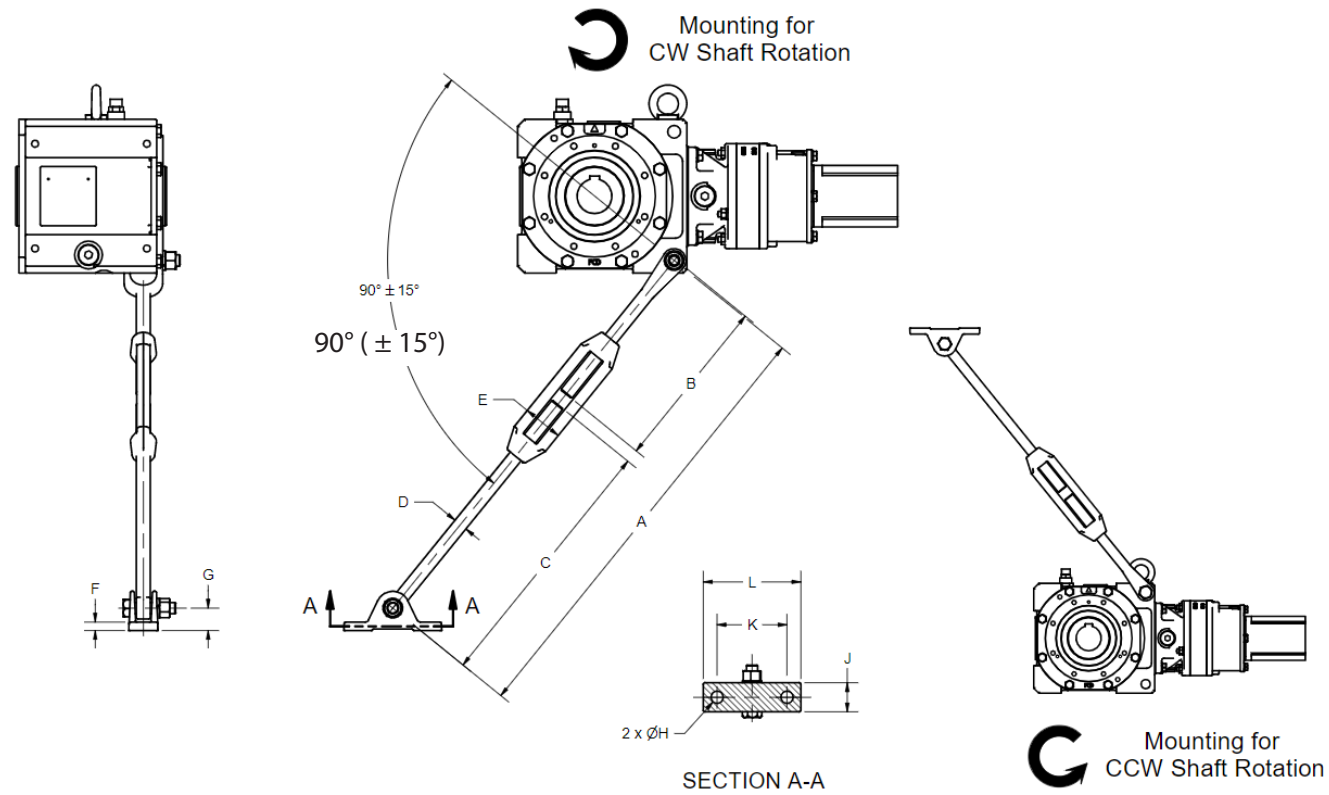


All dimensions are in mm.

Model	Driven Shaft Recommended Dimensions							
	Ødw	Ødw tolerance	Ød1	ØD	ØD tolerance	L1	L2	L3
4A100, 4A105 4A110, 4A115	55.00	h6: +0/-0.019	55.50	56.00	h7: +0/-0.030	258.50	201.00	50.00
4B120, 4B125 4B140, 4B145	65.00	h6: +0/-0.019	65.50	66.00	h7: +0/-0.030	303.50	244.00	50.00

# Torque Arm Turnbuckle Type

# Torque Arm T-Type



All dimensions are in inches (mm).

Turnbuckle Type Torque Arm Dimensions												
Frame Size	A		B	C	D Thread	E	F	G	ØH	J	K	L
	Min	Max										
4A	25.2 (640)	28.7 (730)	9.69 (246)	14.8 (375)	M20	2.24 (57)	0.47 (12.0)	1.26 (32)	0.69 (17.5)	1.65 (42)	3.94 (100)	5.51 (140)
4B	26.0 (660)	29.5 (750)	10.4 (263)	14.8 (375)	M24	2.32 (59)	0.81 (20.5)	2.13 (54)	0.69 (17.5)	2.76 (70)	4.76 (121)	6.61 (168)

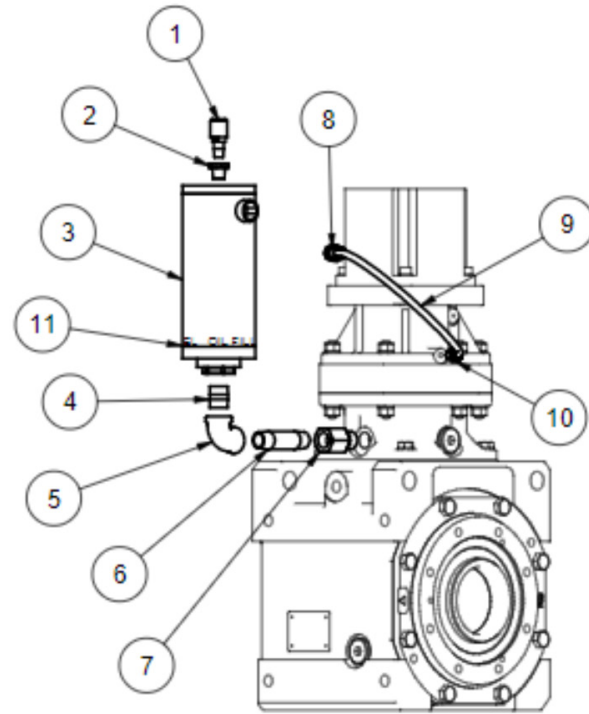
All dimensions are in inches (mm).

T-Type Torque Arm Dimensions								
Frame Size	A	B	C	D		E	F	ØH
				Left <sup>[2]</sup>	Right <sup>[2]</sup>			
4A	7.40 (188)	6.34 (161)	4.25 (108)	1.61 (41)	1.97 (50)	1.18 (30)	0.79 (20)	0.71 (18)
4B	8.98 (228)	7.68 (195)	5.00 (127)	2.09 (53)	2.44 (62)	1.42 (36)	1.13 (29)	0.87 (22)

**Note:** [1] The Cyclo® BBB4 is shown in Y1 mounting position; use two turnbuckle torque arms if application requires shaft rotation in both directions and use torque arm in tension, not compression. Consult Operation and Maintenance Manual or the Factory when mounting in positions other than Y1.  
 [2] Value may vary from shown.  
 [3] Turnbuckle Type torque arm is not available for size F Cyclo(R) BBB4 units. Consult Factory for F-size torque arm type and dimensions.

**Note:** [1] The Cyclo® BBB4 is shown in Y1 mounting position  
 [2] D dimension is from flange-mount casing surface to hole ØH.  
 [3] Turnbuckle Type torque arm is not available for size F Cyclo(R) BBB4 units. Consult Factory for F-size torque arm type and dimensions.

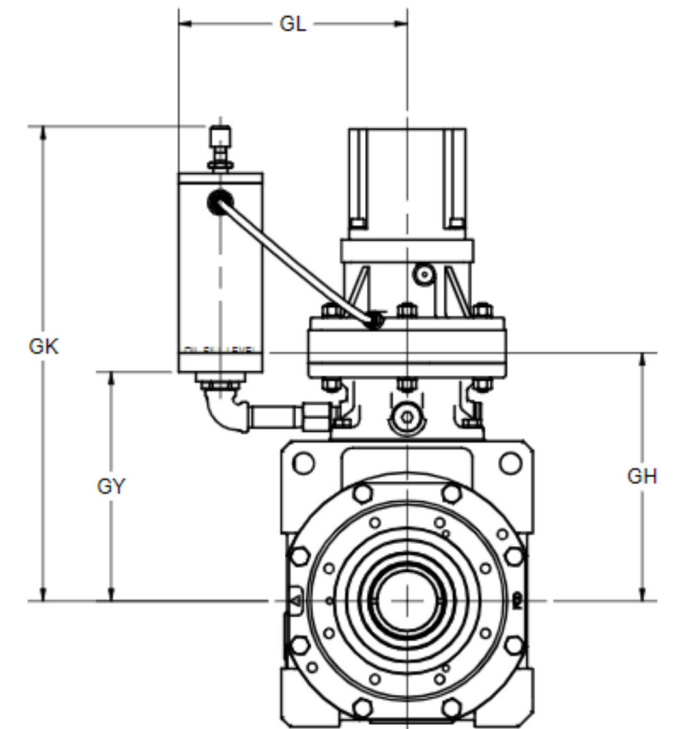
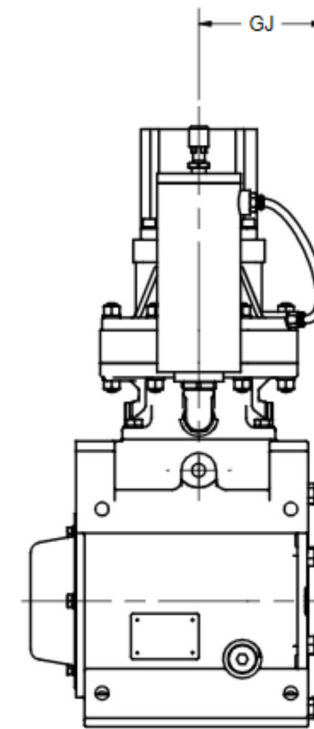
# Clear Oil Fill Cup



Item	Frame Size	Part No.	Description	Qty.
1	ALL	AT1093G	Air Vent	1
2	ALL	332F00R004NG	Reducer bushing	1
3	4A, 4B	TPMR4057-1	4A, 4B fill cup set	1
4	4A10		Nipple, 1/2" npt x 1.5"	1
	4A11			1
	4A12			1
	4B12			1
5	ALL	300F008P--NG	Elbow, 1/2" npt	1
6	4A10	800A008A048NG	Nipple, 1/2" npt x 3"	1
	4A11	800A008A064NG	Nipple, 1/2" npt x 4"	1
	4A12	800A008A056NG	Nipple, 1/2" npt x 3.5"	1
	4B12	800A008A056NG	Nipple, 1/2" npt x 3.5"	1
	4B14	800A008A080NG	Nipple, 1/2" npt x 5"	1
7	ALL	33R008A008NG	Conversion Adapter	1
8	ALL	36MB308E002NG	Push to oil fill cup	1
9	ALL	80MP005095--G	Tubing	1
10	ALL	37LB308E002NG	Push to motor flange	A/R
11	ALL	TMPK5160	Oil fill line sticker	2

Note: Polyalkylene Glycol (PAG)-based oil such as Klübersynth UH1 is not compatible, and cannot be used, with the clear polycarbonate fill cup.

# Clear Oil Fill Cup

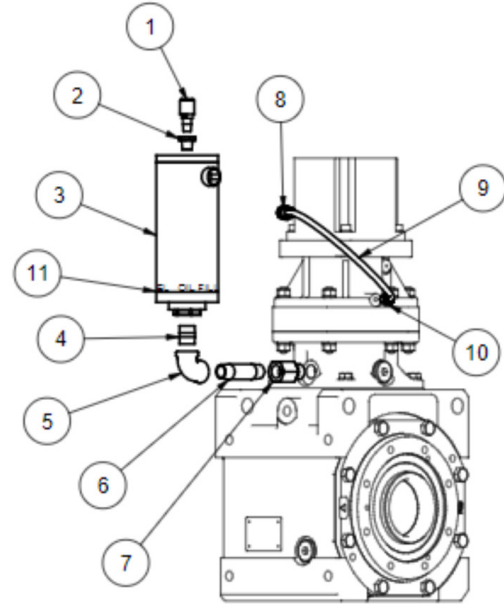


Frame Size	GH	GL	GK	GY	GJ
4A100/5	8.66 (220)	9.09 (231)	18.73 (476)	8.66 (220)	3.78 (96)
4A110/5	8.98 (228)	10.18 (259)	18.74 (476)	8.67 (220)	4.02 (102)
4A120/5	8.90 (226)	9.96 (253)	18.55 (471)	8.47 (215)	5.28 (134)
4A140/5	9.61 (244)	11.89 (302)	18.61 (473)	8.54 (217)	5.28 (134)
4B120/5	10.35 (263)	9.96 (253)	19.99 (508)	9.92 (252)	5.28 (134)
4B140/5	10.87 (276)	11.89 (302)	19.89 (505)	9.82 (250)	5.28 (134)
4B160/5	11.54 (293)	12.79 (325)	19.85 (504)	9.78 (248)	6.61 (168)

Servo BBB

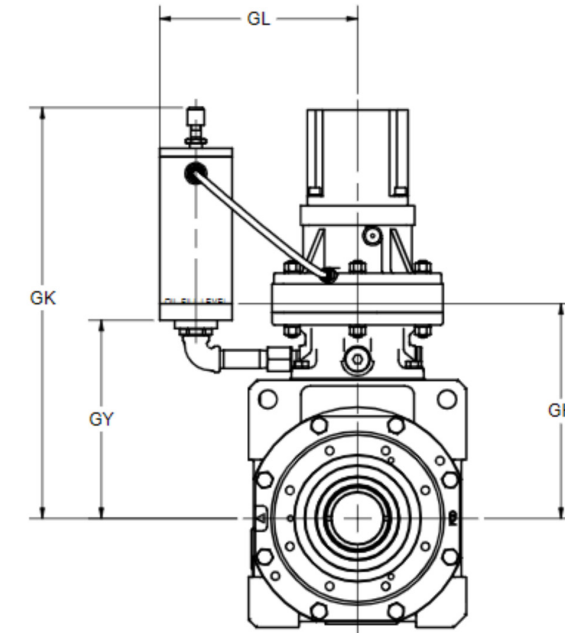
Servo BBB

# Clear Oil Fill Cup



Item	Frame Size	Part No.	Description	Qty.
1	ALL	AT1093G	Air Vent	1
2	ALL	332F00R004NG	Reducer bushing	1
3	4A, 4B	TPMR4057-1	4A, 4B fill cup set	1
4	4A10DA	800A008A032NG	Nipple, 1/2" npt x 2"	1
	4A12DA	800A008A048NG	Nipple, 1/2" npt x 3"	1
	4A12DB			
	4B12DA			
	4B12DB			
5	ALL	300F008P---NG	Elbow, 1/2" npt	1
6	4A10DA	800A008A032NG	Nipple, 1/2" npt x 2"	1
	4A12DA	800A008A048NG	Nipple, 1/2" npt x 3"	1
	4A12DB			
	4B12DA			
	4B12DB			

Item	Frame Size	Part No.	Description	Qty.
7	ALL	33R008A008NG	Conversion Adapter	1
8	ALL	36MB308E002NG	Push to oil fill cup	1
9	ALL	80MP005095--G	Tubing	1
10	ALL	37LB308E002NG	Push to motor flange	A/R
11	ALL	TMPK5160	Oil fill line sticker	2



Frame Size	GH	GL	GK	GY
4A10DA	10.94 (278)	8.09 (205)	19.23 (488)	9.16 (233)
4A12DA	11.42 (290)	9.46 (240)	20.05 (509)	9.97 (253)
4A12DB	11.77 (299)	9.46 (240)	20.05 (509)	9.97 (253)
4B12DA	12.87 (327)	9.46 (240)	21.49 (546)	11.42 (290)
4B12DB	13.23 (336)	9.46 (240)	21.49 (546)	11.42 (290)

# Shaft Diameters - Keyed Hollow Bore

Table 2.1a All dimensions are in inches.

Bore (in)	Frame Size	
	4A	4B
1-7/16"	○	
1-1/2"	○	
1-5/8"	○	
1-11/16"	○	
1-3/4"	○	
1-13/16"	○	○
1-7/8"	○	○
1-15/16"	●◇	○
2"	●◇	○
2-3/16"	●◇	●◇
2-1/4"		○
2-3/8"		●◇
2-7/16"		●◇
2-1/2"		○

Table 2.1b All dimensions are in millimeters.

Bore (mm)	Frame Size	
	4A	4B
35	○	
40	○	
45	○	○
50	○	○
55	●	○
60		○
65		●

- Standard shaft size (Carbon steel material)
- On-demand shaft size (Carbon steel material)
- ◇ Standard Stainless Steel shaft size

Note: 1) The customer is responsible for validating the strength of the driven shaft.  
 2) Consult factory for the price and delivery of 'On-demand' shaft sizes.  
 3) If the required shaft size is different than the above mentioned sizes, please consult the factory.

# Shaft Diameters - Shrink Disc

Table 2.2a All dimensions are in inches.

Bore (in)	Frame Size	
	4A	4B
1-15/16"	●◇	
2"	●◇	●
2-3/16"	●◇	●◇
2-3/8"		●◇
2-7/16"		●◇

Table 2.2b All dimensions are in millimeters.

Bore (mm)	Frame Size	
	4A	4B
55	●	
65		●

- Standard shaft size (Carbon steel material)
- Optional shaft size (Carbon steel material)
- ◇ Standard Stainless Steel shaft size

Note: 1) Shrink disc bore with LEFT as well as RIGHT projections are available (refer figures on page 3.5).  
 2) Shrink disc bore size mentioned in above is ødw dimension of the Table on page 3.6  
 3) If the required shaft size is different than the above mentioned sizes, please consult the factory.

# Shaft Diameters - Taper Grip Bushing

Please refer øU dimensions in 'Dimensions' section for the shaft size range (Min. & Max.)

# Shaft Diameters - Solid Shaft

Table 2.3a All dimensions are in inches.

Bore (in)	Frame Size	
	4A	4B
1-7/16"	○	
1-1/2"	○	
1-9/16"	○	
1-5/8"	○	
1-3/4"	○	
1-7/8"	○	○
1-15/16"	○	○
2"	●	○
2-1/8"	○	○
2-3/16"	○	○
2-1/4"		○
2.236"		○
2-3/8"		○
2-7/16"		○
2-1/2"		○
2-5/8"		○
2-3/4"		○
2-7/8"		●

Table 2.3b All dimensions are in millimeters.

Bore (mm)	Frame Size	
	4A	4B
25	○	
45	○	
50	●	
55		
60		○
65		●

- Standard shaft size (Carbon steel material)
- Optional shaft size (Carbon steel material)

Note: 1) The customer is responsible for validating the strength of the driven shaft.  
 2) Consult factory for the price and delivery of 'On-demand' shaft sizes.  
 3) If the required shaft size is different than the above mentioned sizes, please consult the factory.  
 4) Solid shaft with LEFT, RIGHT as well as DOUBLE EXTENDED projections are available.

# Industry Packages

Three food-grade packages are available for use in machinery where there is incidental food contact.

When ordering, chose the Special Specification Code (SSC) that meets your requirements to obtain the features listed below.

Modication	Chemical Duty	Chemi SHIELD 360*	Low Temp	High Temp	Washdown IP55	Food-Grade	SHIELD 360*	Ultra SHIELD 360*
Epoxy Paint	✓				✓			
FDA Epoxy Paint						✓		
FDA White Top Coat							✓	
FDA Stainless Top Coat	✓	✓						
FDA Stainless Epoxy Top Coat								✓
FDA Grease						✓	✓	✓
Low Temp Grease			✓					
High Temp Grease				✓				
Low Temperature Seals			✓					
High Temperature Seals				✓				
FKM (Viton) Seals	✓							
FKM AM & Chemical Seals		✓					✓	✓
Corrosion Preventative Plugs		✓						✓
Stainless or Tesa Nameplate	✓	✓						✓
Stainless Output Shaft		✓						✓

Stainless Steel Hollow Shaft - ratings with stainless steel hollow shaft are the same as those listed in this catalog for standard models

\* UltraShield360°™ available in quill option only

Servo BBB

Stainless Steel Solid Shaft - maximum torque ratings with standard solid shaft diameters are the same as those listed in this catalog for standard models. Consult the factory when ordering smaller than standard diameters, or if there will be overhung load.

\* UltraShield360°™ available in quill input option only

Low Temp Package = -30 degrees C Maximum. For lower temperature requirements consult factory.

High Temp Package = 50 degrees C Maximum. For higher temperature requirements consult factory.

---

# 4

# Technical Information

---

# Exact Ratios

Bevel Buddybox catalog ratios greater than 18:1 utilize Cyclo as the first (or first and second) reduction stage

Cyclo reduction ratios are exact thus the exact overall Bevel Buddybox reduction ratio can be calculated as:

$$i_{OVERALL} = (Z_{GEAR} / Z_{PINION}) \times i_{CYCLO}$$

where:  $Z_{GEAR}$  = Number of teeth in the bevel gear  
 $Z_{PINION}$  = Number of teeth in the bevel pinion

**Table 2.4 BBB4 with Cyclo Input - Exact Ratios**  
Single Reduction Cyclo

Nominal Ratio	Frame Size	Bevel Gear Tooth Count		Cyclo Ratio ( $i_{CYCLO}$ )	Calculated Ratio $i_{OVERALL}$
		$Z_{GEAR}$	$Z_{PINION}$		
21	ALL <sup>[1]</sup>	35	10	6	21.00
22		32	10	7	22.40
25		35	10	7	24.50
28		35	10	8	28.00
35		32	10	11	35.20
39		35	10	11	38.50
46		35	10	13	45.50
53		35	10	15	52.50
60		35	10	17	59.50
67		32	10	21	67.20
74		35	10	21	73.50
80		32	10	25	80.00
88		35	10	25	87.50
102		35	10	29	101.50
112		32	10	35	112.00
123		35	10	35	122.50
151		35	10	43	150.50
179		35	10	51	178.50
207		35	10	59	206.50
249		35	10	71	304.50
305	35	10	87	416.50	

Note [1]: 22:1 and 25:1 ratios are not available for 4A100/5 and 4A110/5 sizes.

# Special Load Guidelines Overhung Load

## Reducer/Gearmotor Output Shaft Allowable Overhung Load<sup>[1]</sup>

When a sprocket, sheave, or gear is mounted on the slowspeed of a reducer, an overhung load is applied on that shaft. It is necessary to check if the shaft of the Cyclo® BBB4 Speed Reducer will allow the overhung load. Calculate the overhung load using the following formulas:

1) Radial load,  $Pr$

$$Pr = \frac{TI}{R} \leq \frac{Pro}{Lf \cdot Cf \cdot Sf} \quad (\text{lbs, } N)$$

2) Axial Load,  $Pa$

$$Pa \leq \frac{Pao}{Cf \cdot Sf} \quad (\text{lbs, } N)$$

3) When there is combined radial and axial loading on the output shaft

$$\left( \frac{Pr}{Pro} + \frac{Pa}{Pao} \right) \cdot Cf \cdot Sf \leq 1 \quad (\text{lbs, } N)$$

LEGEND

- $Pr$  = Actual radial load (lbs,  $N$ )
- $TI$  = Actual transmitted torque on slow speed shaft of reducer (lb-in,  $N \cdot m$ )
- $R$  = Pitch circle radius of sprocket, gear, pulley, etc. (inch, meter)
- $Pro$  = Allowable radial load (lbs,  $N$ )
- $Pa$  = Actual axial load (lbs,  $N$ )
- $Pao$  = Allowable axial load (lbs,  $N$ )
- $Cf$  = Coupling factor
- $Sf$  = Service factor
- $Lf$  = Load Location factor = 1.0

The values shown in the tables within are the allowable OHL<sup>[2]</sup> when it is applied to the center of the solid shaft extension or at the load-side edge of the hollow bore. Please consult the factory when the center point of the load is located elsewhere.

**Table 2.5 Coupling Factor,  $Cf$**

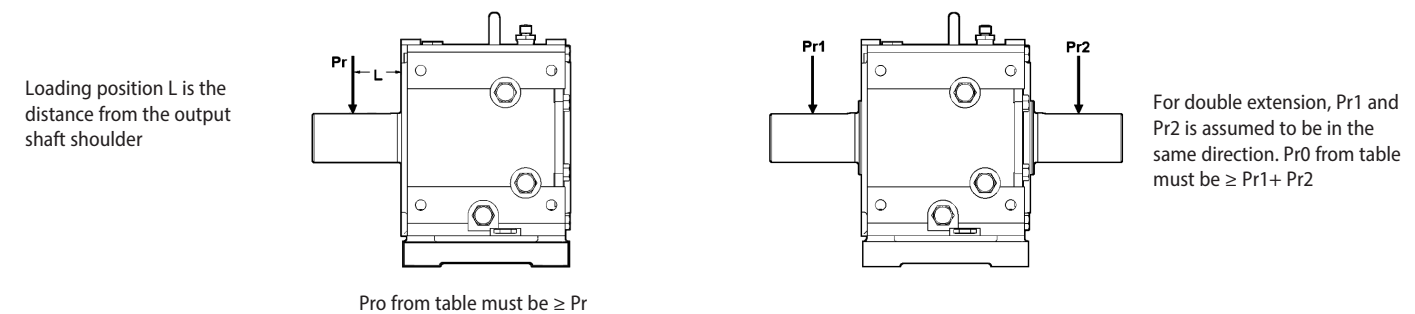
Type of Connection	$Cf$
General Purpose Chain	1.0
Machined Gear, Pinion or Synchronous Belt	1.25
V-Belt	1.5
Flat Belt	2.5

**Table 2.6 Service Factor,  $Sf$**

Shock Factor	$Sf$
No Shock	1.0
Moderate Shock	1.5
Heavy Shock	2.0

### Overhung Load, capacity for solid output shaft

OHL ratings assume there is no axial load applied to the shaft and that the unit is horizontal to floor/foundation. (Mounting feet at bottom or top.) Consult factory when it is wall mount or vertical position. When flange mounted, OHL location should be same side as flange. Consult factory when OHL is opposite flange side. Use ISO/JIS Class 12.9 for mounting hardware.



Note [1]: For output speeds that are in between those detailed in Tables 4.6a through 4.7c, the overhung load capacity may be calculated through interpolation.  
 [2]: OHL = Overhung Load



# Special Load Guidelines Output Shaft Overhung Load continued

# Special Load Guidelines Output Shaft Overhung Load continued

**Table 2.7<sup>[1]</sup> Allowable Overhung Load for Output Shaft (Solid Output Shaft) (Cf, Sf = 1)**

Force Units: lbs, (N)

Model	L inch (mm)	Output Shaft, RPM										
		5	10	20	30	35	45	50	60	75	90	
4A100 4A105 4A110 4A115 4A120 4A125	0.75 (19.1)	7170 (31890)	8360 (37180)	7190 (31980)	6110 (27170)	5740 (25530)	5160 (22950)	4940 (21970)	4570 (20320)	4120 (18320)	3790 (16850)	
	1.00 (25.4)	6850 (30460)	7490 (33310)	6960 (30950)	5940 (26420)	5560 (24730)	5020 (22320)	4790 (21300)	4420 (19660)	3990 (17740)	3670 (16320)	
	1.25 (31.8)	5940 (26420)	6240 (27750)	6240 (27750)	5760 (25620)	5410 (24060)	4870 (21660)	4640 (20630)	4290 (19080)	3890 (17300)	3570 (15870)	
	1.50 (38.1)	5230 (23260)	5340 (23750)	5340 (23750)	5340 (23750)	5260 (23390)	4740 (21080)	4520 (20100)	4170 (18540)	3770 (16760)	3470 (15430)	
	1.75 (44.5)	4670 (20770)	4670 (20770)	4670 (20770)	4670 (20770)	4670 (20770)	4590 (20410)	4390 (19520)	4070 (18100)	3670 (16320)	3370 (14980)	
	1.88 (47.6)	3970 (17650)	4170 (18540)	4170 (18540)	4170 (18540)	4170 (18540)	4170 (18540)	4170 (18540)	3970 (17650)	3570 (15870)	3290 (14630)	
	2.00 (50.8)	3420 (15210)	3740 (16630)	3740 (16630)	3740 (16630)	3740 (16630)	3740 (16630)	3740 (16630)	3740 (16630)	3490 (15520)	3190 (14180)	
	2.50 (63.5)	2970 (13210)	3120 (13870)	3120 (13870)	3120 (13870)	3120 (13870)	3120 (13870)	3120 (13870)	3120 (13870)	3120 (13870)	3040 (13520)	
	3.00 (76.2)	2610 (11600)	2670 (11870)	2670 (11870)	2670 (11870)	2670 (11870)	2670 (11870)	2670 (11870)	2670 (11870)	2670 (11870)	2670 (11870)	
	3.50 (88.9)	2340 (10400)	2340 (10400)	2340 (10400)	2340 (10400)	2340 (10400)	2340 (10400)	2340 (10400)	2340 (10400)	2340 (10400)	2340 (10400)	
	4.00 (102)	2110 (9380)	2080 (9250)	2080 (9250)	2080 (9250)	2080 (9250)	2080 (9250)	2080 (9250)	2080 (9250)	2080 (9250)	2080 (9250)	
	4B120 4B125	0.75 (19.1)	11800 (52480)	11830 (52610)	8810 (39180)	7340 (32640)	6810 (30290)	6010 (26730)	5690 (25300)	5160 (22950)	4570 (20320)	4120 (18320)
		1.00 (25.4)	12350 (54930)	11530 (51280)	8610 (38290)	7160 (31840)	6660 (29620)	5860 (26060)	5560 (24730)	5040 (22410)	4470 (19880)	4020 (17880)
1.25 (31.8)		12620 (56130)	11260 (50080)	8410 (37400)	6990 (31090)	6490 (28860)	5740 (25530)	5440 (24190)	4940 (21970)	4370 (19430)	3920 (17430)	
1.50 (38.1)		11720 (52130)	11010 (48970)	8210 (36510)	6840 (30420)	6340 (28200)	5610 (24950)	5310 (23610)	4820 (21430)	4270 (18990)	3820 (16990)	
1.75 (44.5)		10460 (46520)	10460 (46520)	8040 (35760)	6660 (29620)	6210 (27620)	5460 (24280)	5190 (23080)	4720 (20990)	4170 (18540)	3740 (16630)	
1.88 (47.6)		8870 (39450)	9310 (41410)	7860 (34960)	6540 (29080)	6060 (26950)	5360 (23840)	5060 (22500)	4620 (20540)	4070 (18100)	3670 (16320)	
2.00 (50.8)		7650 (34020)	8360 (37180)	7690 (34200)	6390 (28420)	5940 (26420)	5240 (23300)	4970 (22100)	4520 (20100)	3990 (17740)	3570 (15870)	
2.50 (63.5)		6650 (29570)	6990 (31090)	6990 (31090)	6110 (27170)	5690 (25300)	5020 (22320)	4770 (21210)	4320 (19210)	3820 (16990)	3420 (15210)	
3.00 (76.2)		5870 (26100)	5990 (26640)	5990 (26640)	5890 (26190)	5460 (24280)	4820 (21430)	4570 (20320)	4140 (18410)	3670 (16320)	3290 (14630)	
3.50 (88.9)		5240 (23300)	5240 (23300)	5240 (23300)	5240 (23300)	5240 (23300)	4640 (20630)	4390 (19520)	3990 (17740)	3520 (15650)	3170 (14100)	
4.00 (102)		4720 (20990)	4640 (20630)	4640 (20630)	4640 (20630)	4640 (20630)	4470 (19880)	4240 (18850)	3840 (17080)	3390 (15070)	3040 (13520)	
4.50 (114)		4310 (19170)	4190 (18630)	4190 (18630)	4190 (18630)	4190 (18630)	4190 (18630)	4090 (18190)	3720 (16540)	3270 (14540)	2940 (13070)	
5.00 (127)		3320 (14760)	3490 (15520)	3490 (15520)	3490 (15520)	3490 (15520)	3490 (15520)	3490 (15520)	3470 (15430)	3070 (13650)	2740 (12180)	

**Table 2.8 Allowable Overhung Load for Output Shaft (Keyed Hollow Bore, Shrink Disc, Taper Grip Bushing) (Cf, Sf = 1)**

Force Units: lbs, (N)

Model	L inch (mm)	Output Shaft, RPM										
		5	10	20	30	35	45	50	60	75	90	
4A100 4A105 4A110 4A115 4A120 4A125	0.75 (19.1)	7170 (31890)	8360 (37180)	7510 (33400)	6440 (28640)	6060 (26950)	5490 (24410)	5260 (23390)	4870 (21660)	4440 (19740)	4120 (18320)	
	1.00 (25.4)	7490 (33310)	8190 (36420)	7290 (32420)	6240 (27750)	5890 (26190)	5310 (23610)	5090 (22640)	4740 (21080)	4320 (19210)	3990 (17740)	
	1.25 (31.8)	7610 (33840)	7990 (35530)	7060 (31400)	6060 (26950)	5710 (25390)	5160 (22950)	4940 (21970)	4590 (20410)	4190 (18630)	3870 (17210)	
	1.50 (38.1)	7680 (34160)	7840 (34870)	6860 (30510)	5890 (26190)	5540 (24640)	5020 (22320)	4820 (21430)	4470 (19880)	4070 (18100)	3770 (16760)	
	1.75 (44.5)	7660 (34070)	7660 (34070)	6690 (29750)	5740 (25530)	5390 (23970)	4890 (21750)	4690 (20860)	4340 (19300)	3970 (17650)	3670 (16320)	
	1.88 (47.6)	7150 (31800)	7510 (33400)	6510 (28950)	5590 (24860)	5260 (23390)	4770 (21210)	4570 (20320)	4240 (18850)	3870 (17210)	3570 (15870)	
	2.00 (50.8)	6730 (29930)	7360 (32730)	6340 (28200)	5440 (24190)	5110 (22720)	4640 (20630)	4440 (19740)	4120 (18320)	3770 (16760)	3470 (15430)	
	2.50 (63.5)	6730 (29930)	7060 (31400)	6040 (26860)	5160 (22950)	4870 (21660)	4420 (19660)	4220 (18770)	3920 (17430)	3570 (15870)	3290 (14630)	
	3.00 (76.2)	6680 (29710)	6810 (30290)	5760 (25620)	4940 (21970)	4640 (20630)	4220 (18770)	4040 (17960)	3740 (16630)	3420 (15210)	3140 (13960)	
	3.50 (88.9)	6560 (29170)	6560 (29170)	5490 (24410)	4720 (20990)	4440 (19740)	4020 (17880)	3840 (17080)	3570 (15870)	3240 (14410)	3020 (13430)	
	4.00 (102)	6390 (28420)	6290 (27970)	5260 (23390)	4520 (20100)	4240 (18850)	3840 (17080)	3690 (16410)	3420 (15210)	3120 (13870)	2890 (12850)	
	4B120 4B125	0.75 (19.1)	11800 (52480)	13010 (57860)	10010 (44520)	8510 (37850)	7990 (35530)	7190 (31980)	6890 (30640)	6360 (28280)	5740 (25530)	5290 (23520)
		1.00 (25.4)	12350 (54930)	12680 (56400)	9760 (43410)	8310 (36960)	7790 (34640)	7010 (31180)	6710 (29840)	6190 (27530)	5610 (24950)	5160 (22950)
1.25 (31.8)		12410 (55190)	12380 (55060)	9540 (42430)	8110 (36070)	7610 (33840)	6860 (30510)	6560 (29170)	6060 (26950)	5490 (24410)	5040 (22410)	
1.50 (38.1)		12210 (54310)	12110 (53860)	9310 (41410)	7910 (35180)	7440 (33090)	6690 (29750)	6410 (28510)	5910 (26280)	5340 (23750)	4920 (21880)	
1.75 (44.5)		11910 (52970)	11830 (52610)	9110 (40520)	7740 (34420)	7260 (32290)	6540 (29080)	6260 (27840)	5790 (25750)	5240 (23300)	4820 (21430)	
1.88 (47.6)		10890 (48430)	11430 (50840)	8910 (39630)	7590 (33760)	7110 (31620)	6410 (28510)	6110 (27170)	5660 (25170)	5110 (22720)	4690 (20860)	
2.00 (50.8)		10040 (44650)	10980 (48830)	8710 (38740)	7410 (32950)	6960 (30950)	6260 (27840)	5990 (26640)	5540 (24640)	5020 (22320)	4590 (20410)	
2.50 (63.5)		9680 (43050)	10160 (45190)	8340 (37090)	7110 (31620)	6660 (29620)	6010 (26730)	5740 (25530)	5310 (23610)	4790 (21300)	4420 (19660)	
3.00 (76.2)		9300 (41360)	9490 (42210)	8010 (35620)	6810 (30290)	6410 (28510)	5760 (25620)	5510 (24500)	5090 (22640)	4620 (20540)	4240 (18850)	
3.50 (88.9)		8860 (39400)	8860 (39400)	7710 (34290)	6560 (29170)	6160 (27390)	5540 (24640)	5310 (23610)	4890 (21750)	4440 (19740)	4070 (18100)	
4.00 (102)		8470 (37670)	8340 (37090)	7440 (33090)	6310 (28060)	5940 (26420)	5340 (23750)	5110 (22720)	4720 (20990)	4270 (18990)	3920 (17430)	
4.50 (114)		8090 (35980)	7860 (34960)	7160 (31840)	6090 (27080)	5740 (25530)	5160 (22950)	4940 (21970)	4540 (20190)	4120 (18320)	3790 (16850)	
5.00 (127)		6730 (29930)	7060 (31400)	6690 (29750)	5690 (25300)	5340 (23750)	4820 (21430)	4590 (20410)	4240 (18850)	3840 (17080)	3540 (15740)	

**Note [1]:** For output speeds that are in between those detailed in Tables 4.6a through 4.7c, the overhung load capacity may be calculated through interpolation.

**Note [1]:** For output speeds that are in between those detailed in Tables 4.6a through 4.7c, the overhung load capacity may be calculated through interpolation.

# Special Load Guidelines Inertia

# Special Load Guidelines Inertia continued

**Table 2.9 Reducer Moment of Inertia on Motor Shaft of Gearmotor: Hollow Output Shaft, Ratios 21 - 53<sup>(1)</sup>**  
Units: lb·in<sup>2</sup> (x 10<sup>-4</sup> kg·m<sup>2</sup>)

Model	Nominal Reduction Ratio							
	21	22	25	28	35	39	46	53
<b>4A100</b>	0.462	—	—	0.302	0.186	0.176	0.162	0.141
<b>4A105</b>	(1.35)	—	—	(0.884)	(0.544)	(0.514)	(0.475)	(0.414)
<b>4A110</b>	0.710	—	—	0.491	0.358	0.348	0.304	0.278
<b>4A115</b>	(2.08)	—	—	(1.44)	(1.05)	(1.02)	(0.891)	(0.813)
<b>4A120</b>	1.28	1.44	1.42	0.986	0.608	0.598	0.631	0.589
<b>4A125</b>	(3.74)	(4.21)	(4.14)	(2.89)	(1.78)	(1.75)	(1.85)	(1.72)
<b>4B120</b>	1.62	1.73	1.67	1.18	0.726	0.700	0.704	0.644
<b>4B125</b>	(4.75)	(5.06)	(4.88)	(3.45)	(2.12)	(2.05)	(2.06)	(1.88)

**Table 2.10 Reducer Moment of Inertia on Motor Shaft of Gearmotor: Hollow Output Shaft, Ratios 60 - 305<sup>(1)</sup>**  
Units: lb·in<sup>2</sup> (x 10<sup>-4</sup> kg·m<sup>2</sup>)

Model	Nominal Reduction Ratio												
	60	67	74	80	88	102	112	123	151	179	207	249	305
<b>4A100</b>	0.101	0.107	0.104	0.094	0.092	0.064	0.059	0.058	0.053	0.070	0.047	0.067	0.045
<b>4A105</b>	(0.297)	(0.314)	(0.306)	(0.275)	(0.270)	(0.188)	(0.172)	(0.169)	(0.154)	(0.206)	(0.138)	(0.196)	(0.131)
<b>4A110</b>	0.260	0.227	0.225	0.217	0.215	0.207	0.197	0.196	0.191	0.185	0.183	0.181	0.179
<b>4A115</b>	(0.760)	(0.665)	(0.657)	(0.634)	(0.628)	(0.605)	(0.577)	(0.575)	(0.559)	(0.541)	(0.536)	(0.529)	(0.525)
<b>4A120</b>	0.441	0.496	0.493	0.455	0.453	0.320	0.303	0.302	0.286	0.396	0.272	0.384	0.261
<b>4A125</b>	(1.29)	(1.45)	(1.44)	(1.33)	(1.33)	(0.935)	(0.887)	(0.884)	(0.838)	(1.16)	(0.795)	(1.12)	(0.763)
<b>4B120</b>	0.484	0.528	0.521	0.478	0.473	0.334	0.315	0.312	0.293	0.401	0.275	0.387	0.262
<b>4B125</b>	(1.42)	(1.54)	(1.52)	(1.40)	(1.38)	(0.978)	(0.921)	(0.913)	(0.857)	(1.17)	(0.805)	(1.13)	(0.768)

**Table 2.11 Reducer Moment of Inertia on Motor Shaft of Gearmotor: Solid Shaft [Left (L) or Right (R)] Output, Ratios 21 - 53<sup>(1)</sup>**  
Units: lb·in<sup>2</sup> (x 10<sup>-4</sup> kg·m<sup>2</sup>)

Model	Nominal Reduction Ratio							
	21	22	25	28	35	39	46	53
<b>4A100</b>	0.465	—	—	0.304	0.187	0.177	0.163	0.142
<b>4A105</b>	(1.36)	—	—	(0.890)	(0.547)	(0.517)	(0.477)	(0.415)
<b>4A110</b>	0.713	—	—	0.492	0.359	0.349	0.305	0.278
<b>4A115</b>	(2.09)	—	—	(1.44)	(1.05)	(1.02)	(0.893)	(0.814)
<b>4A120</b>	1.28	1.44	1.42	0.988	0.610	0.599	0.632	0.589
<b>4A125</b>	(3.75)	(4.22)	(4.15)	(2.89)	(1.78)	(1.75)	(1.85)	(1.72)
<b>4B120</b>	1.64	1.74	1.68	1.19	0.731	0.705	0.708	0.646
<b>4B125</b>	(4.79)	(5.10)	(4.91)	(3.48)	(2.14)	(2.06)	(2.07)	(1.89)
<b>4B120</b>	3.76	3.80	3.74	2.49	1.74	1.72	1.37	1.22
<b>4B125</b>	(11.0)	(11.1)	(10.9)	(7.29)	(5.10)	(5.02)	(4.02)	(3.58)

Note: (1) The inertia tables do not include the inertia of the integral motors. Total unit inertia is obtained by adding the reducer inertia to the motor inertia.

**Table 2.12 Reducer Moment of Inertia on Motor Shaft of Gearmotor: Solid Shaft [Left (L) or Right (R)] Output, Ratios 60 - 305<sup>(1)</sup>**  
Units: lb·in<sup>2</sup> (x 10<sup>-4</sup> kg·m<sup>2</sup>)

Model	Nominal Reduction Ratio												
	60	67	74	80	88	102	112	123	151	179	207	249	305
<b>4A100</b>	0.102	0.108	0.105	0.094	0.092	0.064	0.060	0.058	0.053	0.070	0.047	0.067	0.045
<b>4A105</b>	(0.298)	(0.315)	(0.307)	(0.276)	(0.270)	(0.188)	(0.175)	(0.169)	(0.155)	(0.206)	(0.138)	(0.196)	(0.131)
<b>4A110</b>	0.260	0.228	0.225	0.217	0.215	0.207	0.197	0.196	0.191	0.185	0.183	0.181	0.179
<b>4A115</b>	(0.761)	(0.666)	(0.658)	(0.635)	(0.629)	(0.605)	(0.578)	(0.575)	(0.559)	(0.541)	(0.536)	(0.529)	(0.525)
<b>4A120</b>	0.441	0.496	0.493	0.456	0.454	0.320	0.303	0.302	0.286	0.396	0.272	0.384	0.261
<b>4A125</b>	(1.29)	(1.45)	(1.44)	(1.33)	(1.33)	(0.936)	(0.887)	(0.884)	(0.838)	(1.159)	(0.795)	(1.125)	(0.763)
<b>4B120</b>	0.486	0.529	0.522	0.479	0.474	0.335	0.317	0.313	0.293	0.401	0.275	0.387	0.262
<b>4B125</b>	(1.42)	(1.55)	(1.53)	(1.40)	(1.39)	(0.98)	(0.93)	(0.91)	(0.86)	(1.17)	(0.81)	(1.13)	(0.768)

**Table 2.13 Reducer Moment of Inertia on Motor Shaft of Gearmotor: Dual Extended Solid Shaft (T) Output, Ratios 21 - 53<sup>(1)</sup>**  
Units: lb·in<sup>2</sup> (x 10<sup>-4</sup> kg·m<sup>2</sup>)

Model	Nominal Reduction Ratio							
	21	22	25	28	35	39	46	53
<b>4A100</b>	0.482	—	—	0.313	0.193	0.182	0.166	0.145
<b>4A105</b>	(1.41)	—	—	(0.917)	(0.565)	(0.532)	(0.487)	(0.423)
<b>4A110</b>	0.730	—	—	0.502	0.365	0.354	0.309	0.281
<b>4A115</b>	(2.14)	—	—	(1.47)	(1.07)	(1.03)	(0.903)	(0.822)
<b>4A120</b>	1.30	1.46	1.43	0.997	0.616	0.604	0.635	0.592
<b>4A125</b>	(3.80)	(4.27)	(4.18)	(2.92)	(1.80)	(1.77)	(1.86)	(1.73)
<b>4B120</b>	1.68	1.78	1.71	1.21	0.745	0.717	0.716	0.652
<b>4B125</b>	(4.91)	(5.20)	(5.00)	(3.54)	(2.18)	(2.10)	(2.09)	(1.91)
<b>4B120</b>	3.80	3.84	3.76	2.51	1.76	1.73	1.38	1.23
<b>4B125</b>	(11.1)	(11.2)	(11.0)	(7.36)	(5.14)	(5.06)	(4.04)	(3.60)

**Table 2.14 Reducer Moment of Inertia on Motor Shaft of Gearmotor: Dual Extended Solid Shaft (T) Output, Ratios 60 - 305<sup>(1)</sup>**  
Units: lb·in<sup>2</sup> (x 10<sup>-4</sup> kg·m<sup>2</sup>)

Model	Nominal Reduction Ratio												
	60	67	74	80	88	102	112	123	151	179	207	249	305
<b>4A100</b>	0.104	0.109	0.106	0.095	0.093	0.065	0.059	0.058	0.053	0.071	0.047	0.067	0.045
<b>4A105</b>	(0.304)	(0.320)	(0.311)	(0.279)	(0.273)	(0.191)	(0.174)	(0.171)	(0.156)	(0.207)	(0.139)	(0.197)	(0.131)
<b>4A110</b>	0.262	0.229	0.226	0.218	0.216	0.208	0.198	0.197	0.191	0.185	0.183	0.181	0.180
<b>4A115</b>	(0.767)	(0.671)	(0.662)	(0.638)	(0.632)	(0.607)	(0.579)	(0.576)	(0.560)	(0.541)	(0.537)	(0.530)	(0.526)
<b>4A120</b>	0.443	0.498	0.495	0.457	0.455	0.321	0.304	0.303	0.287	0.396	0.272	0.384	0.261
<b>4A125</b>	(1.30)	(1.46)	(1.45)	(1.34)	(1.33)	(0.938)	(0.889)	(0.886)	(0.839)	(1.16)	(0.795)	(1.13)	(0.763)
<b>4B120</b>	0.490	0.533	0.525	0.482	0.476	0.337	0.317	0.314	0.294	0.401	0.276	0.387	0.263
<b>4B125</b>	(1.44)	(1.56)	(1.54)	(1.41)	(1.39)	(0.985)	(0.926)	(0.918)	(0.860)	(1.18)	(0.807)	(1.13)	(0.769)

Note: (1) The inertia tables do not include the inertia of the integral motors. Total unit inertia is obtained by adding the reducer inertia to the motor inertia.

# Special Load Guidelines Misc.

# Lubrication

## Excessive Overloads

Servo BBB4 gearboxes provide 200% momentary intermittent shock load capacity and are warranted for two years from date of shipment. Refer to our standard terms and conditions for our complete warranty.

## Selection for Applications Involving Shock Loading

For applications involving frequent start-stops, review the recommendations in the selection procedure. For braking or reversing, or quick starting of loads having large inertia, consult factory for model selection or recommended modifications.

## Allowable Radial and Thrust Loads

The loads imposed on the reducer shafts vary with the method of connecting the shaft to the driven machine. Frequently, in addition to torsional forces, radial and thrust loads are applied to the slow speed shaft at the same time. For example, coupling connections normally involve torsional forces only. However, when power is transmitted through spur gears, belts, pulleys or chains, both torsional

and radial forces may be applied to the reducer shafts. When driving through helical or bevel gears, all three conditions (torsional, radial and thrust load) may be referred to the reducer shaft.

The reducer shafts and bearings must have sufficient strength to withstand these loads, and it is, therefore, necessary to determine the allowable limits for each condition. Please consult a Sumitomo Application Engineer for further information.

## Load Centering

The radial load capacities are calculated with the load concentrated at the midpoint of the slow speed shaft extension. Radial load capacities decrease if the center of the load is moved farther from the reducer and the values obtained from the charts must be adjusted accordingly.

## Oil lubricated models are not filled with oil prior to shipping.

Before operating, fill the unit with the appropriate amount of the correct lubricant for the mounting position (see Table 2.12). When operating in winter or other relatively low ambient temperatures, use the lower viscosity oil specified for each ambient temperature range. Please consult the factory if the unit will be operated consistently in ambient temperatures other than 14°F to 104°F (-10° to 40°C).

## Grease lubricated models are lubricated with grease prior to shipment from the factory.

NOTE: For units supplied in the Y4 mounting position (input shaft vertical down), the Cyclo® portion is filled at the factory with grease. For these units, the Cyclo® portion does not need to be filled with lubricant before start-up. The Bevel Gear portion of models built for the Y4 mounting configuration still requires filling with gear oil before start-up. Refer to the unit Operating and Maintenance manual for further details.

Adding grease prior to initial start-up is not required. If grease must be replenished or changed avoid using greases other than those shown in the Table 2.12. Please consult the factory when the units will be used in widely fluctuating temperatures, ambient temperatures other than those specified in Table 2.13, or when other special conditions exist for the application. When motors from another manufacturer will be used, please consult and adhere to the associated motor maintenance manual for the appropriate lubrication instructions.

**Oil lubricated units** are shipped without oil. Prior to initial start-up, the unit must be filled with the correct amount of oil.

**Grease lubricated models** are lubricated at the factory. Additional grease does not need to be added prior to initial start-up.

## Oil Replenishment and Change Interval

- A. Maintain proper oil levels at all times.
- B. An oil change after the first 500 hours of operation is highly recommended.
- C. Sumitomo recommends an oil change every 2500 hours, or six months, whichever comes first. If a proper preventive maintenance program is implemented and maintained, a longer change period may be acceptable.
- D. For any operating conditions outside our standard (page xx), consult factory for recommendations.

## Grease Replenishment and Change Interval

For units ordered for mounting in the Y4 configuration (motor vertical down), please consult the Operating and Maintenance manual for proper grease replenishment and change interval for the Cyclo® portion.

\*VG68 is not available for ExxonMobil Spartan.

\*\*Shell Gadus S2 V220 NLGI 0 can be used for 4A100 and 4A105 sizes only

Table 2.15 Lubrication Type

Unit Size	Output (Bevel Gear Portion)	Input (Cyclo® Portion)		
		Motor Horizontal	Motor Vertical Up	Motor Vertical Down
All	Oil	Oil	Oil	Grease

### Approved Oils:

<b>ExxonMobil</b>	Spartan EP	<b>Idemitsu</b>	Daphne Super Gear Oil	<b>BP</b>	Energol GR-XP
<b>ExxonMobil</b>	Mobilgear 600XP	<b>Kluber</b>	Kluberoll GEM1	<b>Castrol</b>	Alpha SP
<b>ExxonMobil</b>	Mobil SHC Gear Hi-Shock 150	<b>Caltex</b>	Meropa	<b>Gulf</b>	EP Lubricant HD
				<b>Shell</b>	Omala S2 G

Table 2.16 Ambient Temperatures

°F	14	32	50	68	86	104	122
°C	-10	0	10	20	30	40	50
ISO VG	68* (14° F to 41° F)						
	100 / 150 (32° F to 95° F)						
				220 / 320 / 460 (86° F to 122° F)			

**Food Grade Oil:** Klüber: Klübersynth UH1 6-460

Table 2.17 Standard Greases

Ambient Temperature °F (°C)	Reduction Ratio	Input (Cyclo® Portion)
14° to 122°F (-10° to 50°C)	11 through 18:1	N/A**
	19:1 and higher	Exxon Unirex N2

Table 2.18 Food Grade Grease

Ambient Temperature °F (°C)	Reduction Ratio	Input (Cyclo® Portion)
14° to 122°F (-10° to 50°C)	11 through 18:1	N/A
	19:1 and higher	Ultrachem Omnilube FGM2

# Lubrication continued

## Oil Quantities

Be sure to check the oil level with the oil gauge. The following listed oil quantity is an approximation.

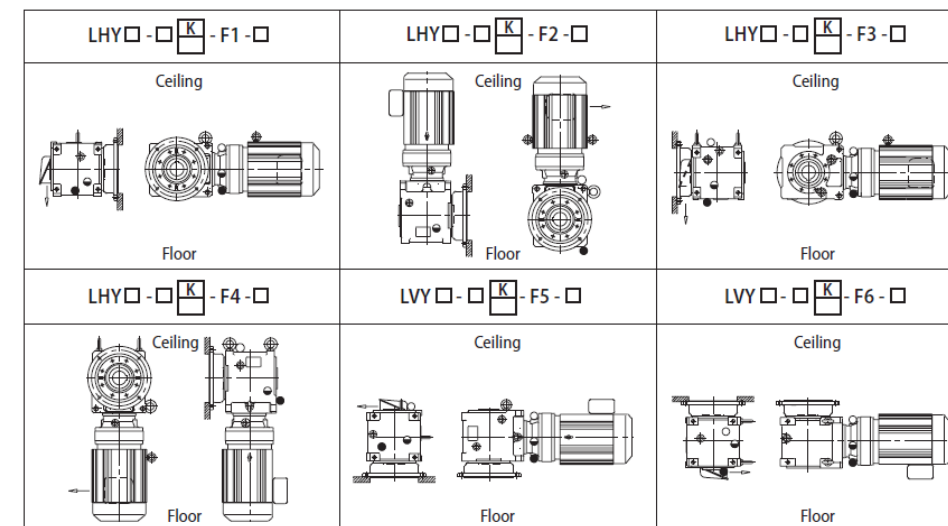
**Table 2.19 BBB with Single Reduction Cyclo - Approximate Oil Quantity**

Units: US liquid gallon (*liter*) **Note: Output =** Bevel Gear Portion **Input =** Cyclo® Portion

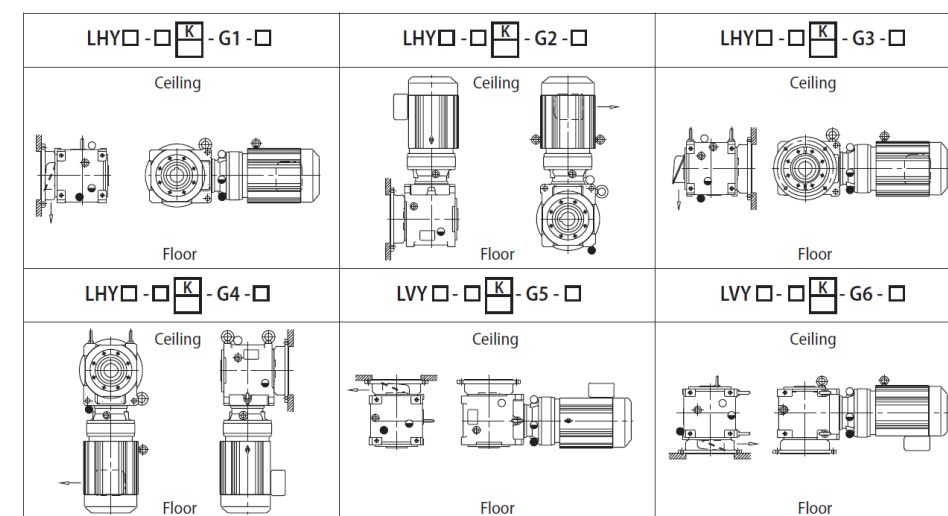
Bevel Gear Unit Size	Mounting Configuration					
	Y1	Y3	Y2	Y4	Y5	Y6
4A10	0.43 (1.62)		0.84(3.17)		0.36 (1.36)	0.49 (1.84)
4A11	0.44 (1.66)		0.86(3.26)	0.30 (1.13) Grease	0.37 (1.40)	0.50 (1.88)
4A12	0.45 (1.71)		0.88 (3.35)		0.38 (1.45)	0.51 (1.93)
4B12	0.87 (3.29)		1.72 (6.50)	0.45 (1.72) Grease	0.88 (3.34)	0.85 (3.23)

# Additional Mounting Configurations

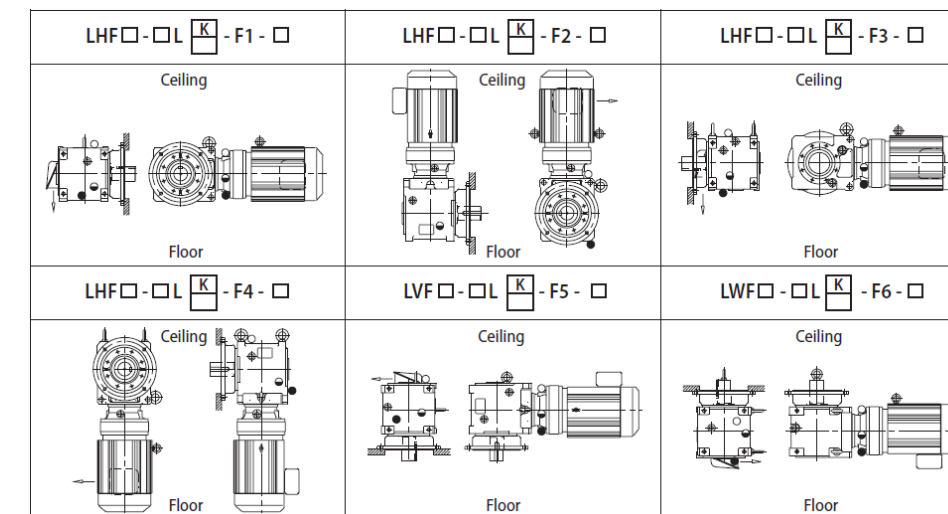
**Fig. 2.20 Keyed Hollow Output Bore – Output Flange Left**



**Fig. 2.21 Keyed Hollow Output Bore – Output Flange Right**



**Fig. 2.22 Solid Output Shaft (L) - Output Flange Left**



# Additional Mounting Configurations

Fig. 2.23 Solid Output Shaft Right (R) - Output Flange t Right

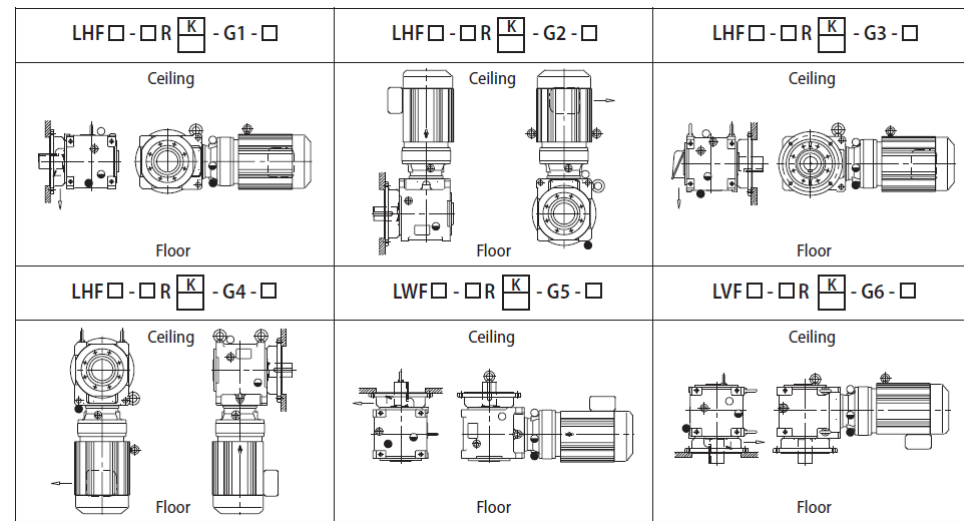


Fig. 2.24 Double Extended Solid Output Shaft (T) - Output Flange Left

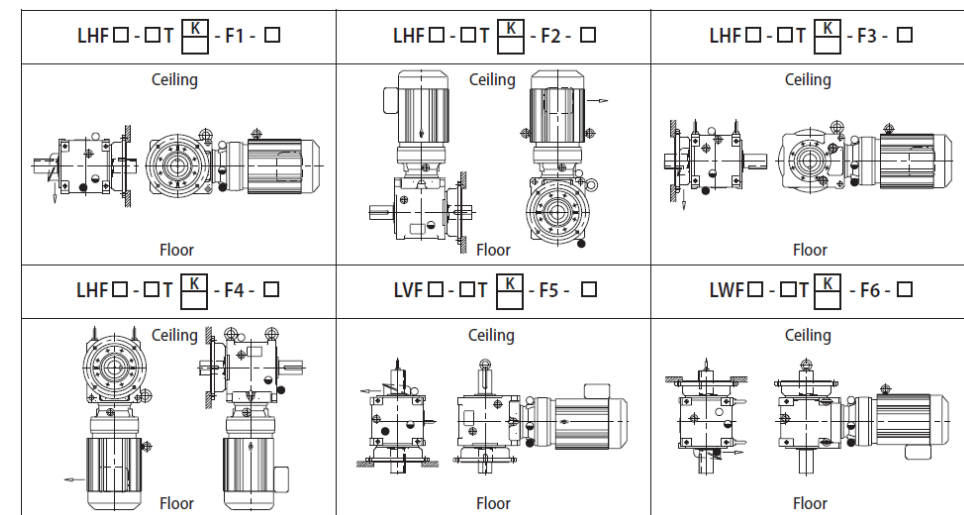


Fig. 2.25 Double Extended Solid Output Shaft (T) - Output Flange Right

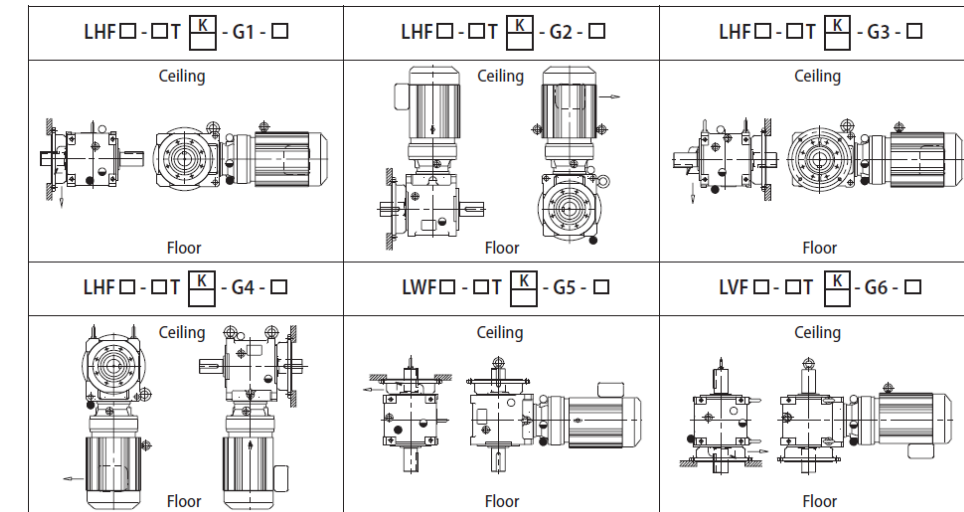


Fig. 2.26 Solid Output Shaft Left (L) - Output Flange Right

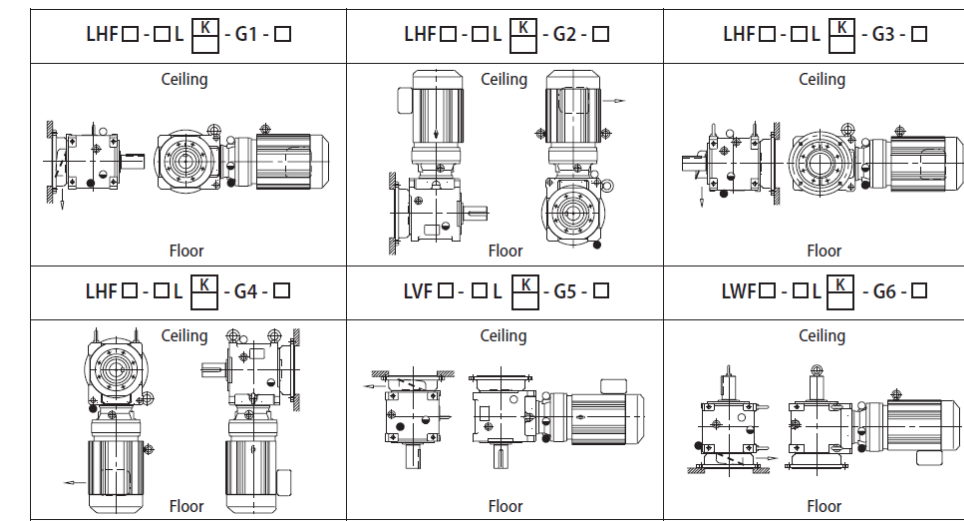


Fig. 2.27 Solid Output Shaft Right (R) - Output Flange Left

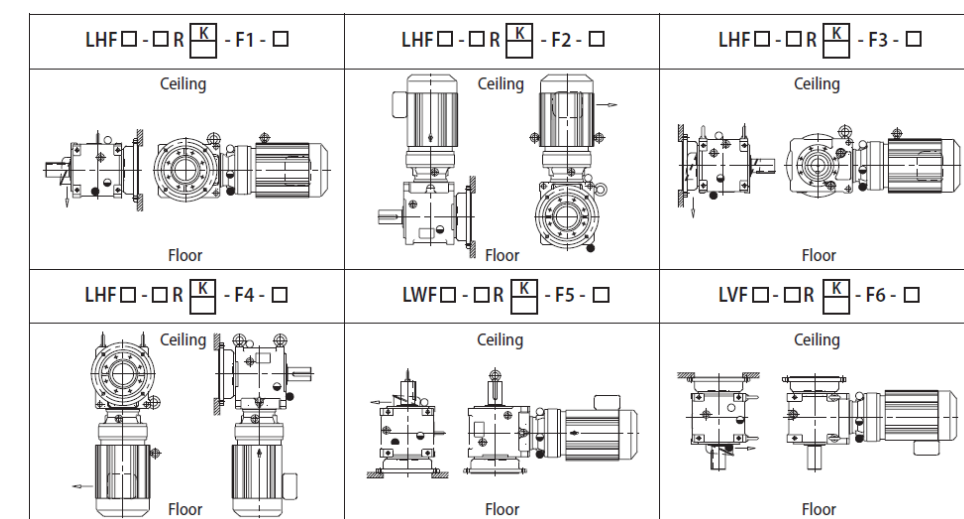
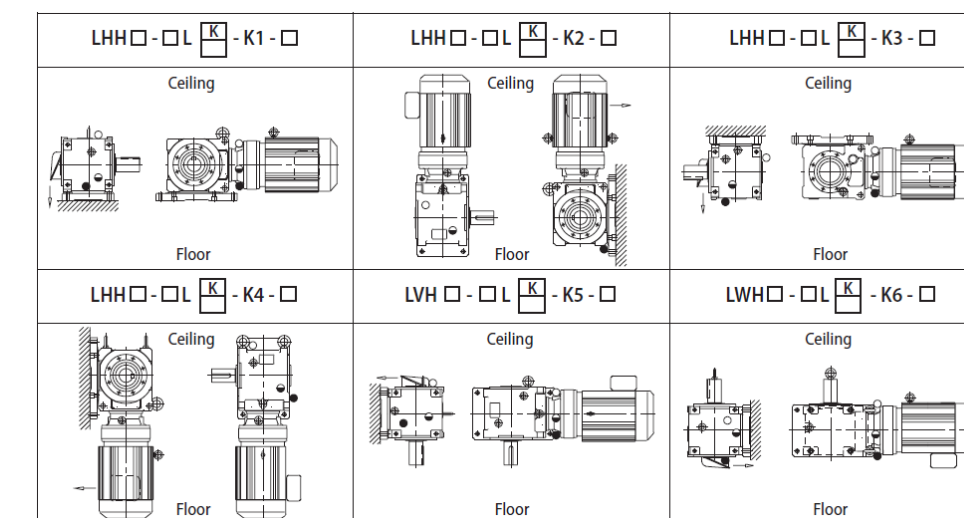


Fig. 2.28 Solid Output Shaft Left (L) - Mounting Foot Bottom



Servo BBB

Servo BBB

# Additional Mounting Configurations

Fig. 2.29 Solid Output Shaft Right (R) - Mounting Foot Bottom

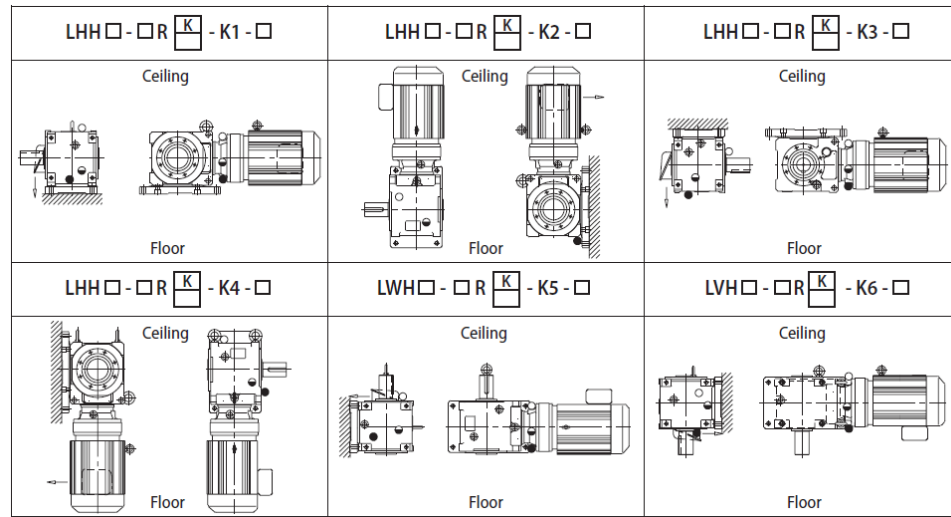


Fig. 2.30 Double Extended Solid Output Shaft (T) - Mounting Foot Bottom

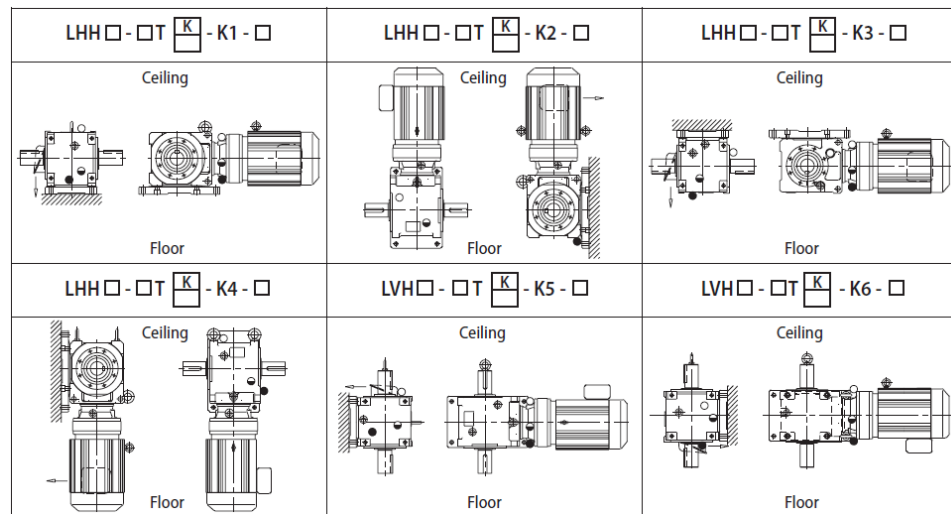
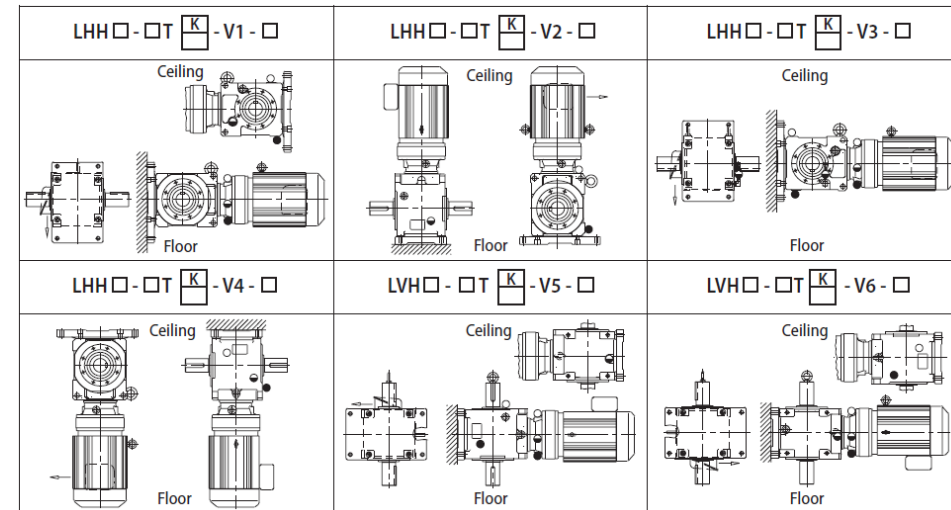


Fig. 2.31 Double Extended Solid Output Shaft (T) - Mounting Foot Side



# Additional Mounting Configurations

Fig. 2.32 Solid Output Shaft Left (L) - Mounting Foot Side

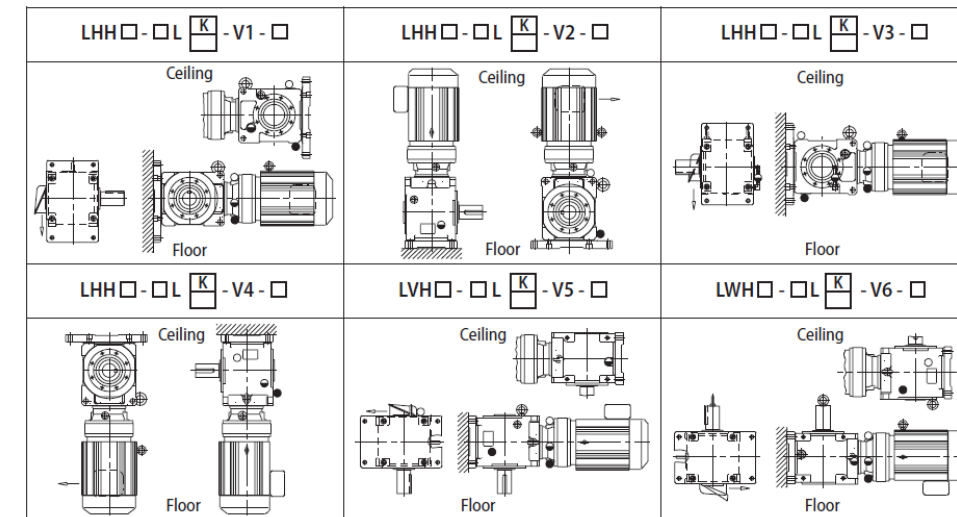


Fig. 2.33 Solid Output Shaft Right (R) - Mounting Foot Side

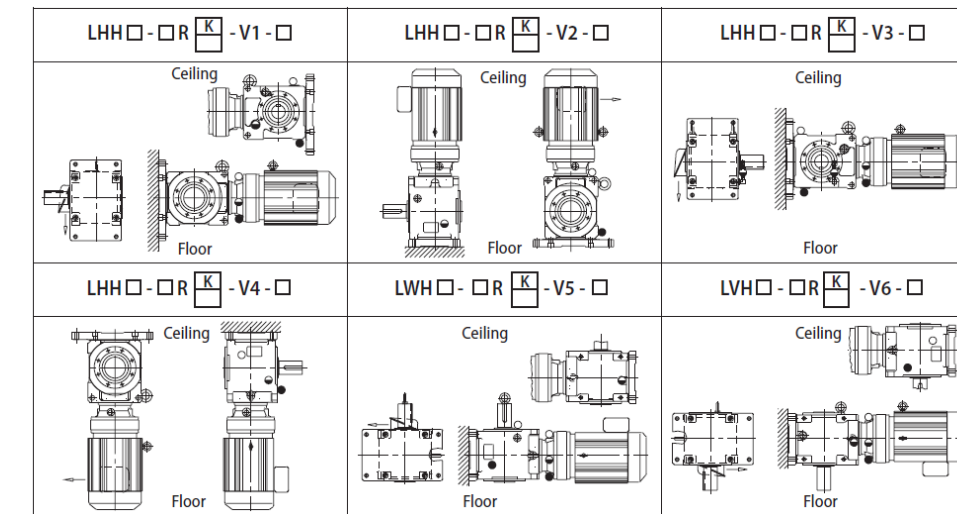
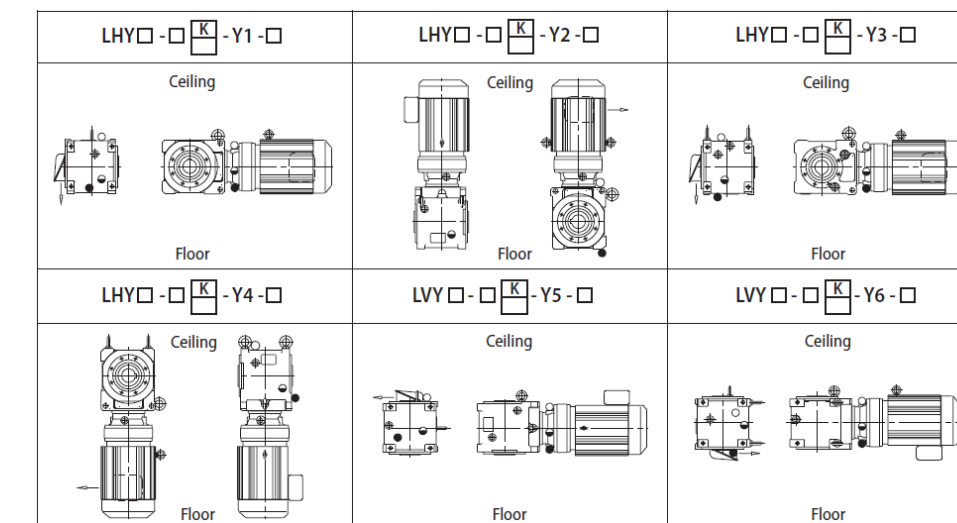


Fig. 2.34 Keyed Hollow Bore Output Bore



# Warranty

Sumitomo warrants that its Servo BBB4 will deliver their continuous catalog ratings and up to 200% intermittent SHOCK LOAD CAPACITY, provided they are properly installed, maintained and operated within the limits of speed, torque or other load conditions under which they were sold. Sumitomo further states that Servo BBB4 are warranted to be free from defects in material or workmanship for a period of two years from the date of shipment. Sumitomo assumes no liability beyond product repair or replacement under this limited warranty.

For construction purposes, be sure to obtain certified dimension sheets or drawings. Although Sumitomo takes every precaution to include accurate data in our catalog, Sumitomo cannot guarantee such accuracy. If performance guarantees are required, they should be obtained in writing from the factory. Full consideration will be given to such requests when complete details are given of the proposed installation.

Page intentionally left blank.

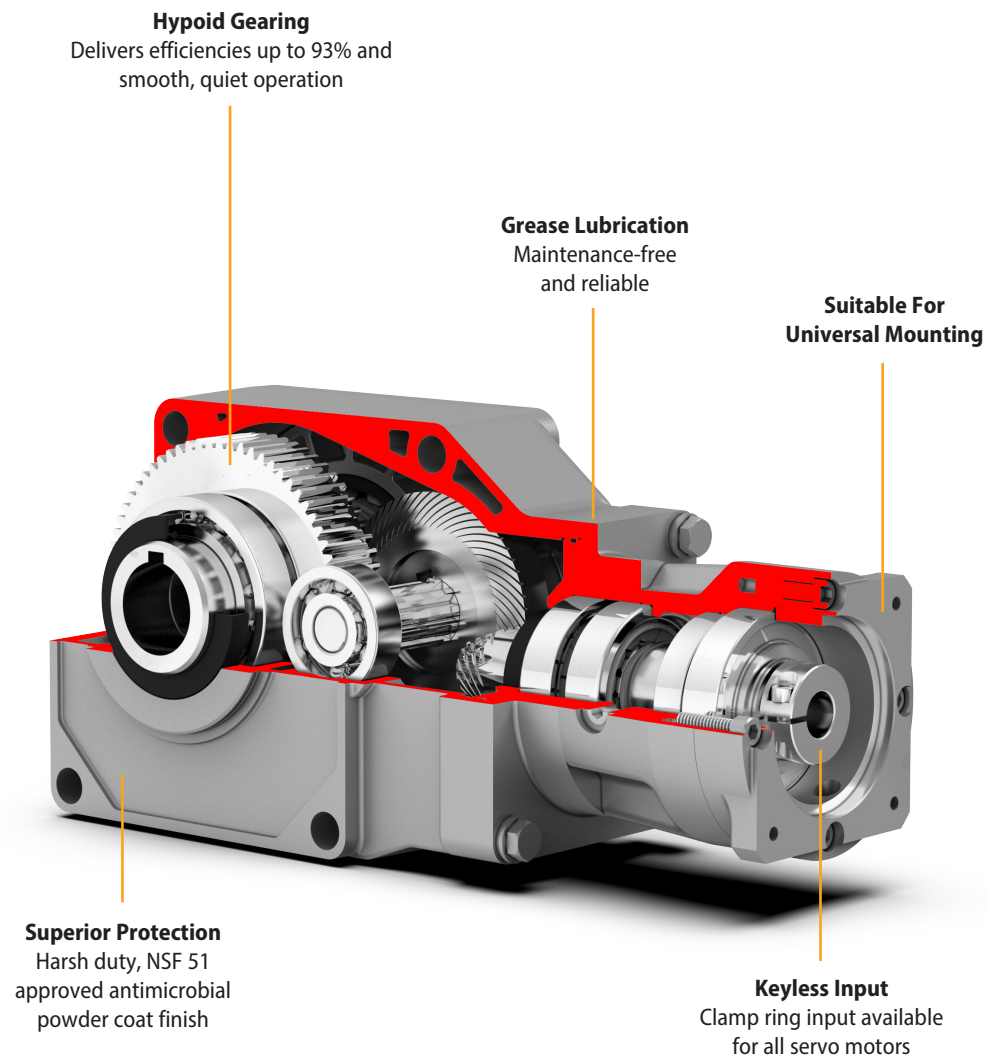
**Table 2.35 - Product Warranty**

Product	Warranty Period (After Shipment)	Components Excluded
Cyclo® Speed Reducers and Gearmotors	2 Years	Bearings and Seals
Cyclo® Bevel Buddybox Speed Reducers and Gearmotors	2 Years	Bearings and Seals
Cyclo® Helical Buddybox Speed Reducers and Gearmotors	2 Years	Bearings and Seals
Fine Cyclo® Speed Reducers	2 Years	Bearings and Seals
Beier® Variator Mechanical Adjustable Speed Reducers	2 Years	Bearings and Seals
Hyponic® Speed Reducers and Gearmotors	2 Years	Bearings and Seals
Hedcon® Double Enveloping Worm Gear Speed Reducers	2 Years	Bearings and Seals
Helical Shaft Mount Speed Reducers	2 Years	Bearings and Seals
Rhytax®	2 Years	Bearings and Seals
IB Series Servo Gearheads	1 Year	Bearings and Seals
Astero Gearmotors	1 Year	Bearings and Seals
Variable Frequency Inverters	1 Year	---
Paramax® Speed Reducers	2 Years	Bearings and Seals
Compower Planetary Speed Reducers	1 Year	Bearings and Seals
Hansen UniMiner	2 Years	Bearings and Seals
Hansen P4	2 Years	Bearings and Seals
Parts	1 Year	---
Repairs	1 Year	Bearings and Seals

Servo BBB

Servo BBB

► Grease lubricated design is maintenance free, requires no oil changes, and is up to 93% gear efficiency across all ratios



## Product Description

The Sumitomo Servo Hyponic® Gearbox represents 60 years of excellence in the design and manufacture of premium gearing solutions. With millions of Hyponics currently in service, the product features a compact, modular housing, **maintenance-free grease lubrication and high efficiency operation.** Options include keyed hollow bore input for any servo motor design; unique FKM antimicrobial, multi-lipped rotary output seal; corrosion resistant, stainless output shaft and hardware; and synthetic NSF H-1, food-grade lubricant. NSF51 antimicrobial powder coating makes Hyponic® the ideal choice for food, beverage, and pharmaceutical industries. Sumitomo's patented, all-steel hypoid gear technology leads the industry in quiet operation and high efficiency. The Hyponic® significantly outperforms worm gearing for all ratios.

## Features & Benefits

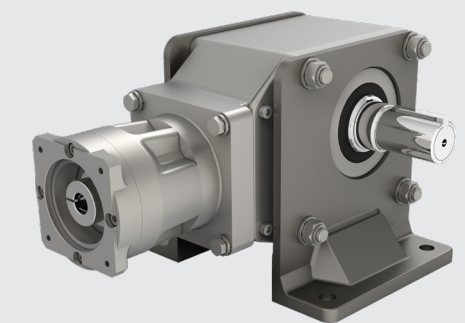
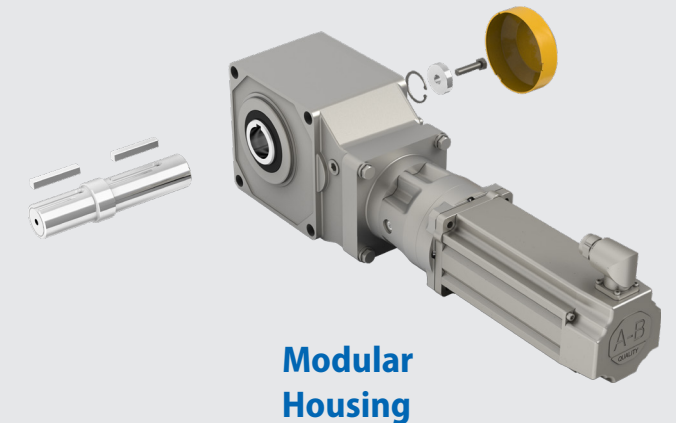
Patented Hyponic gear technology is up to **93% gear efficiency** across all ratios and requires no cooling fan.

- **NSF 51 approved antimicrobial powder coating** protects against the growth of bacteria, mold, and fungus
- **All-steel hypoid gear design** transmits torque more efficiently for more torque density in a compact unit
- **Maintenance-free grease lubrication** eliminates oil changes
- **Compact, lightweight** design in an aluminum, corrosion-resistant housing with optional washdown protection
- Hollow Output Bore makes **installation and retrofit quick and easy**
- **Extremely quiet**, smooth operation is ideal for commercial use
- **Two-Year warranty**

## General Specifications Summary

<b>Ratios:</b>	3.5:1 up to 60:1
<b>kW:</b>	0.069 to 1.54
<b>Maximum Torque:</b>	269 Nm
<b>Housing:</b>	Lightweight, Corrosion-Resistant Aluminum
<b>Mounting:</b>	Flange, Bolt-On Feet
<b>Output Shafts:</b>	Hollow, Solid
<b>Input:</b>	Keyed Hollow Bore

► **Optional plug-in shaft and bolt-on feet** enhance Hyponic® mounting flexibility



## Quiet, Compact and Maintenance-Free

► Hardened steel hypoid gear design transmits torque more efficiently for more torque density in a compact unit



## Applications

- Bottling & Food Processing
- Commercial Bakery Lines
- Pharmaceutical Machinery
- Automotive Assembly Plants
- Conveyor Lines & Material Handling
- Residential Elevators & Lifts
- Automated Bay & Dock Door Drives
- Dehydrators
- Packaging



# Product Range

Nominal Ratio (:1) Output RPM (1750 rpm input)	5 350	7 250	10 175	12 145.83	15 116.67	20 87	25 70	30 58.33	40 43.75	50 35	60 29.17
0.1 kW	Size 1120, Bore Ø0.75"								Size 1220, Bore Ø1.00"		
0.2 kW	Size 1120, Bore Ø0.75"								Size 1220, Bore Ø1.00"		
	Size 1220, Bore Ø1.00"								Size 1320, Bore Ø1.25"		
0.25 kW	Size 1220, Bore Ø1.00"								Size 1320, Bore Ø1.25"		
0.37 kW	Size 1220, Bore Ø1.00"								Size 1320, Bore Ø1.25"		
	Size 1320, Bore Ø1.25"								Size 1420, Bore Ø1.375"		
0.55 kW	Size 1320, Bore Ø1.25"								Size 1420, Bore Ø1.375"		
0.75 kW	Size 1320, Bore Ø1.25"								Size 1420, Bore Ø1.375"		
	Size 1420, Bore Ø1.375"										
1.1 kW	Size 1420, Bore Ø1.375"										
1.5 kW	Size 1420, Bore Ø1.375"										

Note: [1] This frame size is torque limited. Overload may occur if the motor is loaded to its full capacity. Sumitomo recommends the use of a torque limiting device to protect the unit and/or the driven machine.

# FAQs

## How do I select a Servo Hyponic® gearbox?

Selection is based on the actual torque and speed requirements at the output shaft. The Servo Hyponic® gearbox has particularly high efficiencies over a wide range of reduction ratios, which frequently permits the use of reduced input power requirements (smaller HP or kW motor) without sacrificing output shaft torque. The selection procedures in this catalog will guide you in choosing the most efficient reducer for your application.

## What are Service Factors and how are they used?

In general, reducers are rated for the specific conditions and operating requirements of the application by the use of AGMA-defined Service Factors. The Service Factors are used in the product selection process to adjust for the specific conditions and operating requirements of your application.

## What do I do if my application has particularly severe operating conditions?

The standard ratings for Servo Hyponic® are based on 10-hour daily service under conditions of uniform loads (equivalent to AGMA service factor 1.0). By following the product selection process, you will determine and apply the Service Factors to compensate for the severe operating conditions.

## What are the advantages of a shrink disc?

The shrink disc provides for easy mounting and removal to and from the shaft of the driven machine. Because it requires no keyway, the shaft isn't weakened and maximum torque is transmitted.

## What kind of torque arm do I specify?

The standard torque arm is shown on page 3.37. The Servo Hyponic® gearbox does not ship with a torque arm unless customer specifies.

## Can the Servo Hyponic® be mounted in any position?

All frame sizes come standard grease lubricated and can be mounted in any position. Food-grade grease and oil lubrication is available upon customer request.

---

Page intentionally left blank.

# 2

# How to Configure

---

# Configure a Model Number

# Nomenclature

### Output Shaft Orientation

Type	Prefix
Universal Direction (Maintenance Free)	N

### Mounting Style

Type	Prefix
Shaft Mount (Hollow Shaft)	Y

### Input Connection

Input Connection	Prefix
Clamp Ring	X

### Modification

	Prefix
Special	S
Standard	

### Frame Size

- 1120
- 1220
- 1320
- 1420

### Output Shaft Direction (solid shaft only)

Direction (when viewed from motor end)	Suffix
Projects to Left Side	L
Projects to Right Side	R
Projects to Both Sides	T

\*For dimensions refer to page 4.2 to 4.5

### Shaft Specifications

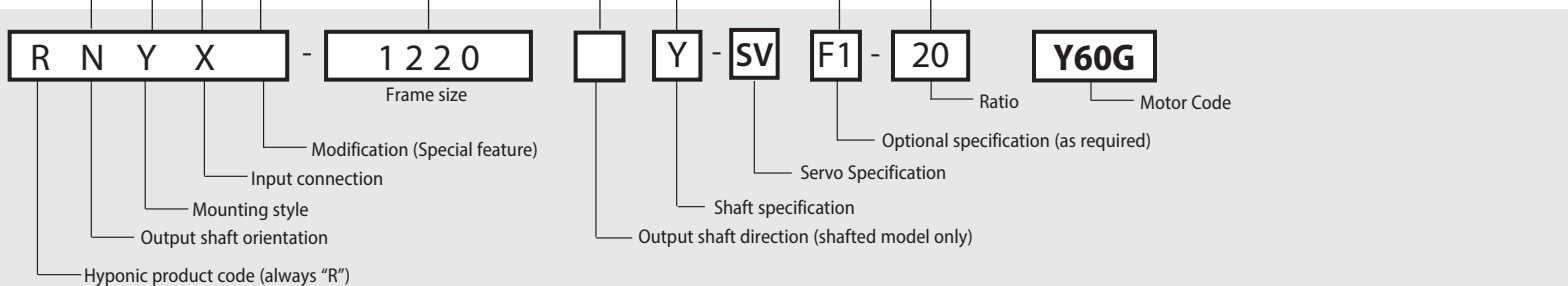
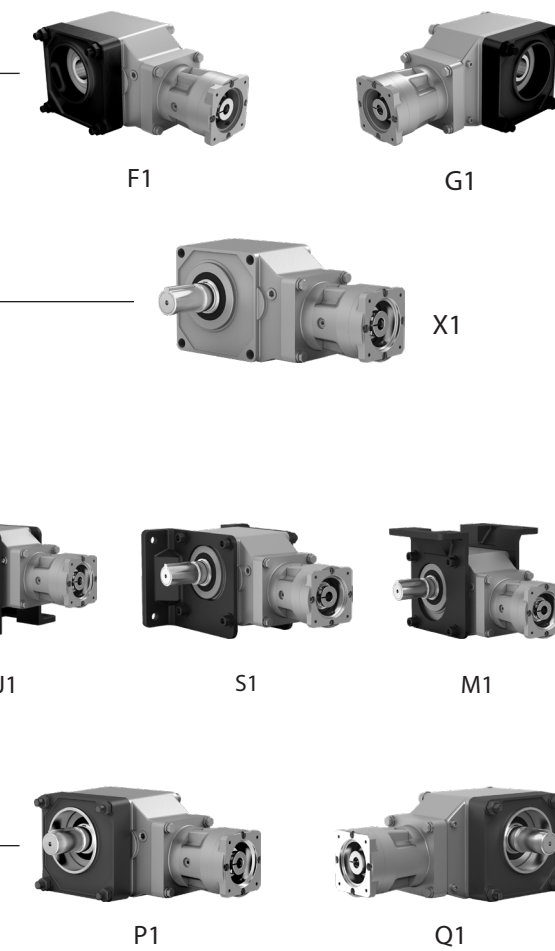
Input Shaft	Output Shaft		Suffix
	Hollow	Solid	
Metric (JIS)	Key (Inch)	Key (Inch)	
Metric (DIN)	-	Key (mm)	E
Inch	Key (Inch)	Key (Inch)	Y

### Optional Specifications (as required)

Specification	Code
<b>Hollow Bore Options</b>	
<b>Flange (Extended or Metric) page 4.5 (for motor clearance)</b>	
Left (viewed from motor end)	F1
Right (viewed from motor end)	G1
<b>Solid Shaft Options pages 4.2-4.3</b>	
Plug-in Shaft	X1
<b>Plug-in Shaft with Bolt-on Feet page 4.4</b>	
Bottom	J1
Opposite from Motor	S1
Top	M1
<b>Plug-in Shaft with Flange (Extended or Metric) page 4.5 (for motor clearance)</b>	
Left (viewed from motor end)	P1
Right (viewed from motor end)	Q1

### Nominal Total Ratio

5	20	60
7	25	
10	30	
12	40	
15	50	



**Nomenclature Example:**  
**RNYX - 1220Y - SVF1 - 20 Y60G**

R – Hyponic®	1220 – Frame Size
N – Universal Mount	Y – Inch Shaft Specification
Y – Shaft Mount (Hollow Shaft)	SV – Servo Specification
X – Hollow Input Shaft	F1 – Extended flange on Left side (viewed from motor end)
	Ratio – 20

# Rating Tables

# Rating Tables

Size	Ratio	Input Speed								Allowable Max Input Speed r/min	Allowable Peak Torque at Startup and Stop N·m
		3000 r/min				2000 r/min					
		Allowable Input Power kW	Rated Output Torque N·m	Allowable Radial Load N	Max %ED %	Allowable Input Power kW	Rated Output Torque N·m	Allowable Radial Load N	Max %ED %		
1120	5	0.2	2.71	441	50	0.2	4.06	539	50	3600	5.61
	7	0.2	3.79	490		0.2	5.69	637			7.85
	10	0.2	5.42	588		0.2	8.13	686			11.2
	12	0.2	6.5	637		0.2	9.75	735			13.5
	15	0.2	8.13	686		0.2	12.2	785			16.8
	20	0.2	10.8	785		0.2	16.3	883			22.4
	25	0.2	13.5	834		0.2	20.3	932			28
	30	0.2	16.3	883		0.2	24.4	981			33.6
	40	0.1	10.8	981		0.1	16.3	1080			22.4
	50	0.1	13.5	1030		0.1	20.3	1180			28
60	0.1	16.3	1080	0.1	24.4	1230	33.6				
1220	5	0.4	5.4	637	50	0.4	8.13	785	50	3600	11.21
	7	0.4	7.6	735		0.4	11.4	883			15.69
	10	0.4	10.8	883		0.4	16.3	981			22.4
	12	0.4	13	932		0.4	19.5	1030			26.9
	15	0.4	16.3	981		0.4	24.4	1130			33.6
	20	0.4	21.7	1080		0.4	32.5	1230			44.8
	25	0.4	27.1	1130		0.4	40.6	1320			56.1
	30	0.4	32.5	1230		0.4	48.8	1420			67.3
	40	0.2	21.7	1370		0.2	32.5	1520			44.8
	50	0.2	27.1	1470		0.2	40.6	1620			56.1
60	0.2	32.5	1520	0.2	48.8	1670	67.3				

Size	Ratio	Input Speed								Allowable Max Input Speed r/min	Allowable Peak Torque at Startup and Stop N·m
		1500 r/min				1000 r/min					
		Allowable Input Power kW	Rated Output Torque N·m	Allowable Radial Load N	Max %ED %	Allowable Input Power kW	Rated Output Torque N·m	Allowable Radial Load N	Max %ED %		
1120	5	0.2	5.42	637	100	0.138	5.61	686	100	3600	5.61
	7	0.2	7.59	686		0.138	7.85	785			7.85
	10	0.2	10.8	785		0.138	11.2	883			11.2
	12	0.2	13	834		0.138	13.5	932			13.5
	15	0.2	16.3	883		0.138	16.8	981			16.8
	20	0.2	21.7	981		0.138	22.4	1080			22.4
	25	0.2	27.1	1030		0.138	28	1180			28
	30	0.2	32.5	1080		0.138	33.6	1230			33.6
	40	0.1	21.7	1180		0.069	22.4	1320			22.4
	50	0.1	27.1	1270		0.069	28	1320			28
60	0.1	32.5	1320	0.069	33.6	1320	33.6				
1220	5	0.4	10.8	883	100	0.276	11.21	981	100	3600	11.21
	7	0.4	15.2	981		0.276	15.69	1080			15.69
	10	0.4	21.7	1080		0.276	22.4	1230			22.4
	12	0.4	26	1130		0.276	26.9	1270			26.9
	15	0.4	32.5	1230		0.276	33.6	1420			33.6
	20	0.4	43.3	1370		0.276	44.8	1520			44.8
	25	0.4	54.2	1470		0.276	56.1	1620			56.1
	30	0.4	65	1520		0.276	67.3	1670			67.3
	40	0.2	43.3	1620		0.138	44.8	1770			44.8
	50	0.2	54.2	1720		0.138	56.1	1810			56.1
60	0.2	65	1770	0.138	67.3	1810	67.3				



# Rating Tables

# Rating Tables

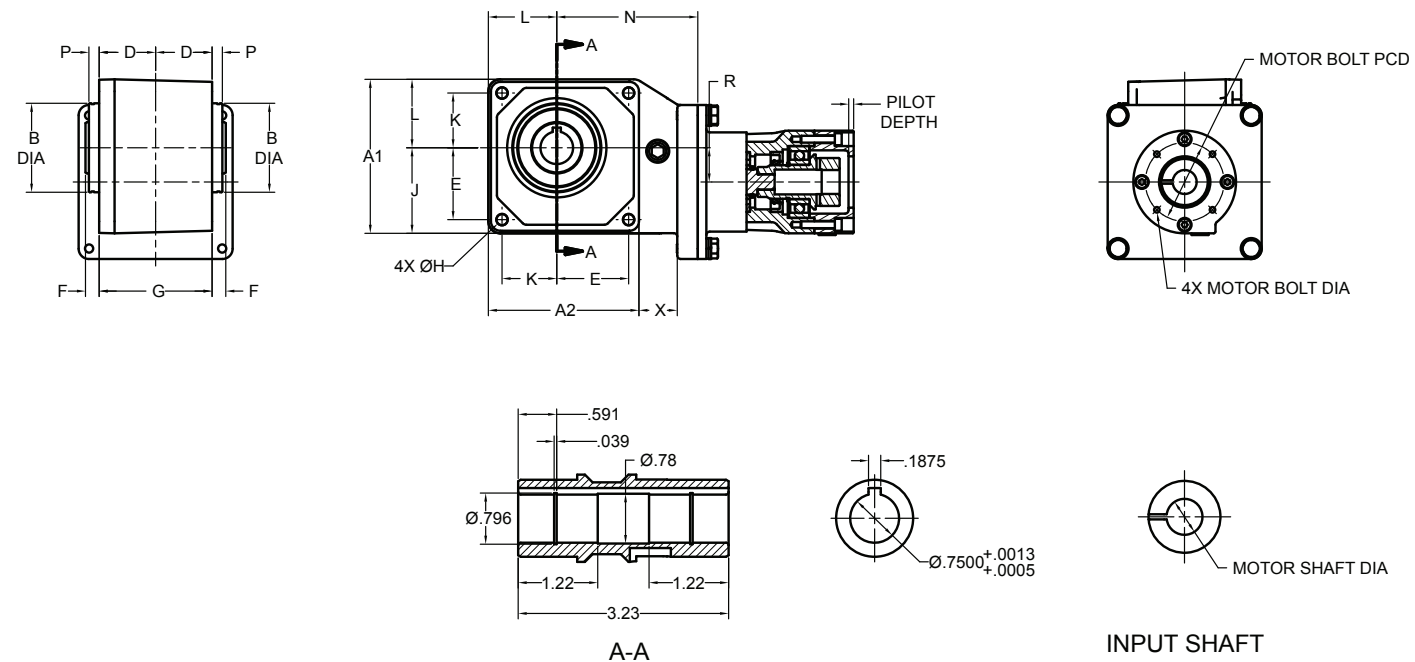
Size	Ratio	Input Speed								Allowable Max Input Speed r/min	Allowable Peak Torque at Startup and Stop N·m
		3000 r/min				2000 r/min					
		Allowable Input Power kW	Rated Output Torque N·m	Allowable Radial Load N	Max %ED %	Allowable Input Power kW	Rated Output Torque N·m	Allowable Radial Load N	Max %ED %		
1320	5	0.8	10.8	1080	50	0.8	16.3	1270	50	3600	22.4
	7	0.8	15.2	1230		0.8	22.8	1470			31.4
	10	0.8	21.7	1470		0.8	32.5	1670			44.8
	12	0.8	26	1570		0.8	39	1770			53.8
	15	0.8	32.5	1670		0.8	48.8	1860			67.3
	20	0.8	43.3	1810		0.8	65	2060			89.7
	25	0.8	54	1960		0.8	81.3	2210			112
	30	0.8	65	2060		0.8	97.5	2300			135
	40	0.4	43.3	2210		0.4	65	2450			89.7
	50	0.4	54	2350		0.4	81.3	2600			112
60	0.4	65	2450	0.4	97.5	2750	135				
1420	5	1.54	20.9	1670	50	1.54	31.3	1960	50	3600	43.2
	7	1.54	29.2	1860		1.54	43.8	2210			60.4
	10	1.54	41.7	2160		1.54	62.6	2450			86.3
	12	1.54	50.1	2300		1.54	75.1	2650			104
	15	1.54	62.6	2450		1.54	93.9	2840			129
	20	1.54	83.4	2750		1.54	125	3090			173
	25	1.54	104	2940		1.54	156	3290			216
	30	1.54	125	3090		1.54	188	3430			259
	40	0.8	86.7	3330		0.8	130	3730			179
	50	0.8	108	3530		0.8	163	3920			224
60	0.8	130	3730	0.8	195	4070					

Size	Ratio	Input Speed								Allowable Max Input Speed r/min	Allowable Peak Torque at Startup and Stop N·m
		1500 r/min				1000 r/min					
		Allowable Input Power kW	Rated Output Torque N·m	Allowable Radial Load N	Max %ED %	Allowable Input Power kW	Rated Output Torque N·m	Allowable Radial Load N	Max %ED %		
1320	5	0.8	21.7	1470	100	0.552	22.4	1670	100	3600	22.4
	7	0.8	30.3	1670		0.552	31.4	1810			31.4
	10	0.8	43.3	1810		0.552	44.8	2060			44.8
	12	0.8	52	1910		0.552	53.8	2160			53.8
	15	0.8	65	2060		0.552	67.3	2300			67.3
	20	0.8	84.7	2260		0.552	89.7	2450			89.7
	25	0.8	108	2350		0.552	112	2650			112
	30	0.8	130	2450		0.552	135	2790			135
	40	0.4	86.7	2650		0.276	89.7	2940			89.7
	50	0.4	108	2840		0.276	112	3090			112
60	0.4	130	2940	0.276	135	3090	135				
1420	5	1.54	41.7	2160	100	1.062	43.2	2500	100	3600	43.2
	7	1.54	58.4	2450		1.062	60.4	2750			60.4
	10	1.54	83.4	1750		1.062	86.3	3090			86.3
	12	1.54	100	2840		1.062	104	3240			104
	15	1.54	125	3090		1.062	129	3430			129
	20	1.54	167	3330		1.062	173	3730			173
	25	1.54	209	3530		1.062	216	3920			216
	30	1.54	250	3730		1.062	259	4070			259
	40	0.8	173	3970		0.552	179	4310			179
	50	0.8	217	4170		0.552	224	4360			224
60	0.8	260	4310	0.552	269	4360	269				



# Dimensions

## Frame Size 1100 RNYX-1120Y



All dimensions are in inches (mm)

Model	A1	A2	B min	B max	D	E	F	G	H	J	K	L	N	P	R	X
1120Y	3.54 (90)	3.47 (88)	2.046 (51.97)	2.0472 (52)	1.30 (33)	1.65 (42)	0.31 (8)	2.60 (66)	0.26 (6.6)	1.97 (50)	1.26 (32)	1.57 (40)	3.23 (82)	0.24 (6)	0.79 (20)	0.87 (22)

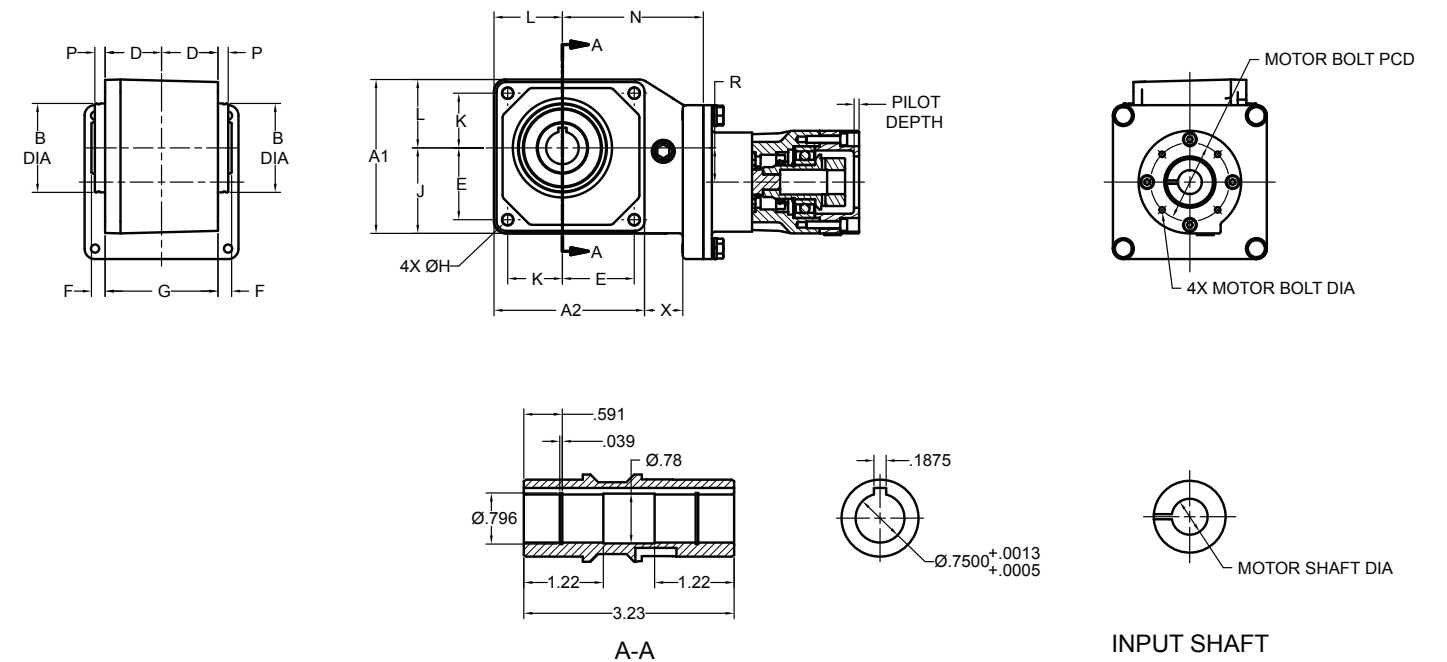
Model	Ratio	NEMA Frame	CE	C	AK	BD	AJ	BF	Z	BB	ZA	Wt. (lbs.)
RNYX-1120Y	5~60	56C	7.87 (200)	7.56 (192)	4.5 (114.3)	6.69 (170)	5.875 (149.2)	0.43 (11)	0.39 (10)	0.22 (5.5)	-	8 (3.5)

Model	NEMA Frame	XU	XU Tolerance	XV
RNYX-1120Y	56C	0.625	+0.0017 / +0.0009	1.82

Dimensions shown are for reference only and are subject to change without notice, unless certified. Certified prints are available after receipt of an order; consult factory.

# Dimensions

## Frame Size 1200 RNYX-1220



All dimensions are in inches (mm)

Model	A1	A2	B min	B max	D	E	F	G	H	J	K	L	N	P	R	X
1220Y	4.53 (115)	4.45 (113)	3.0697 (77.97)	3.0709 (78)	1.46 (37)	2.24 (57)	0.35 (9)	2.91 (74)	0.35 (9)	2.60 (66)	1.57 (40)	1.93 (49)	3.78 (96)	0.20 (5)	1.10 (28)	0.79 (20)

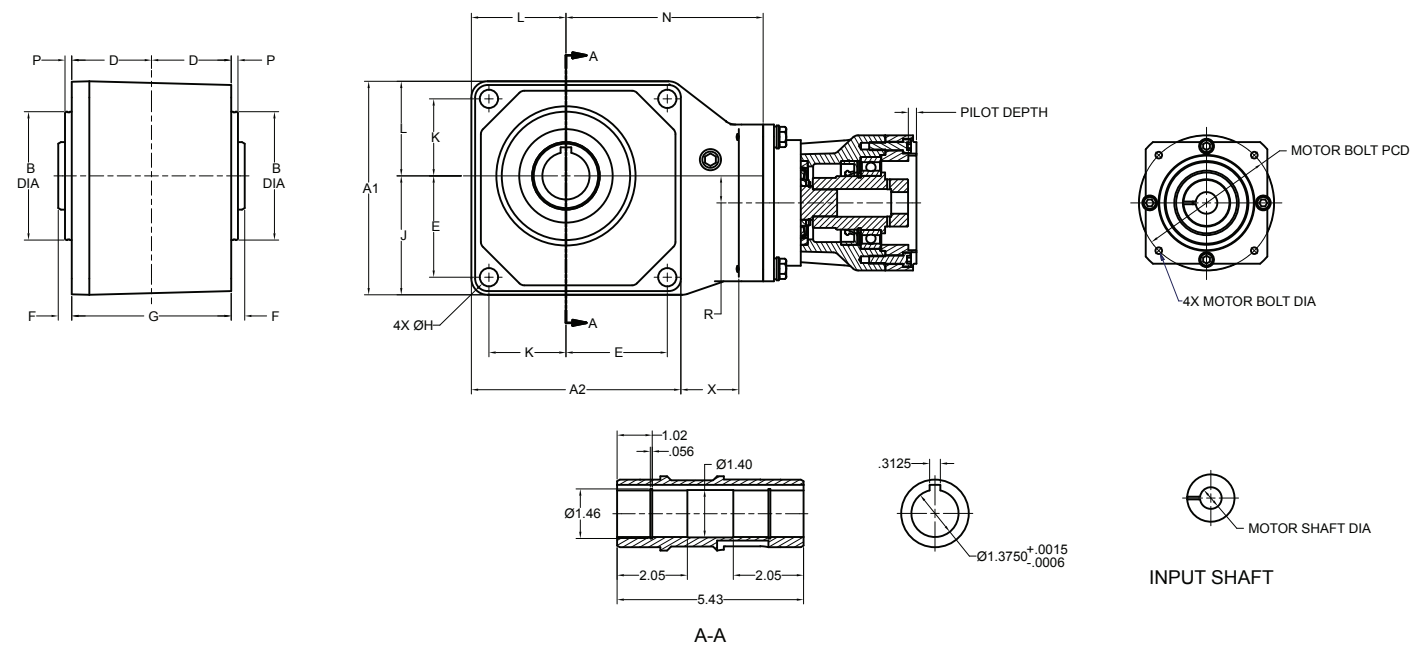
Model	Ratio	NEMA Frame	CE	C	AK	BD	AJ	BF	Z	BB	ZA	Wt. (lbs.)
RNYX-1220Y	5~60	56C	9.17 (233)	8.86 (225)	4.50 (114.3)	6.69 (170)	5.875 (149.2)	0.43 (11)	0.39 (10)	0.22 (5.5)	-	11 (5)

Model	NEMA Frame	XU	XU Tolerance	XV
RNYX-1220Y	56C	0.625	+0.0017 / +0.0009	1.85

Dimensions shown are for reference only and are subject to change without notice, unless certified. Certified prints are available after receipt of an order; consult factory.

# Dimensions

## Frame Size 1300 RNYX-1320



All dimensions are in inches (mm).

Per NEMA standard

Model	A1	A2	B min	B max	D	E	F	G	H	J	K	L	N	P	R	X
<b>1320Y</b>	5.20 (132)	5.12 (130)	3.3451 (84.965)	3.3464 (85.000)	1.81 (46)	2.44 (62)	0.35 (9)	3.62 (92)	0.43 (11)	2.91 (74)	1.81 (46)	2.28 (58)	4.69 (119)	0.20 (5)	1.08 (27.5)	1.34 (34)

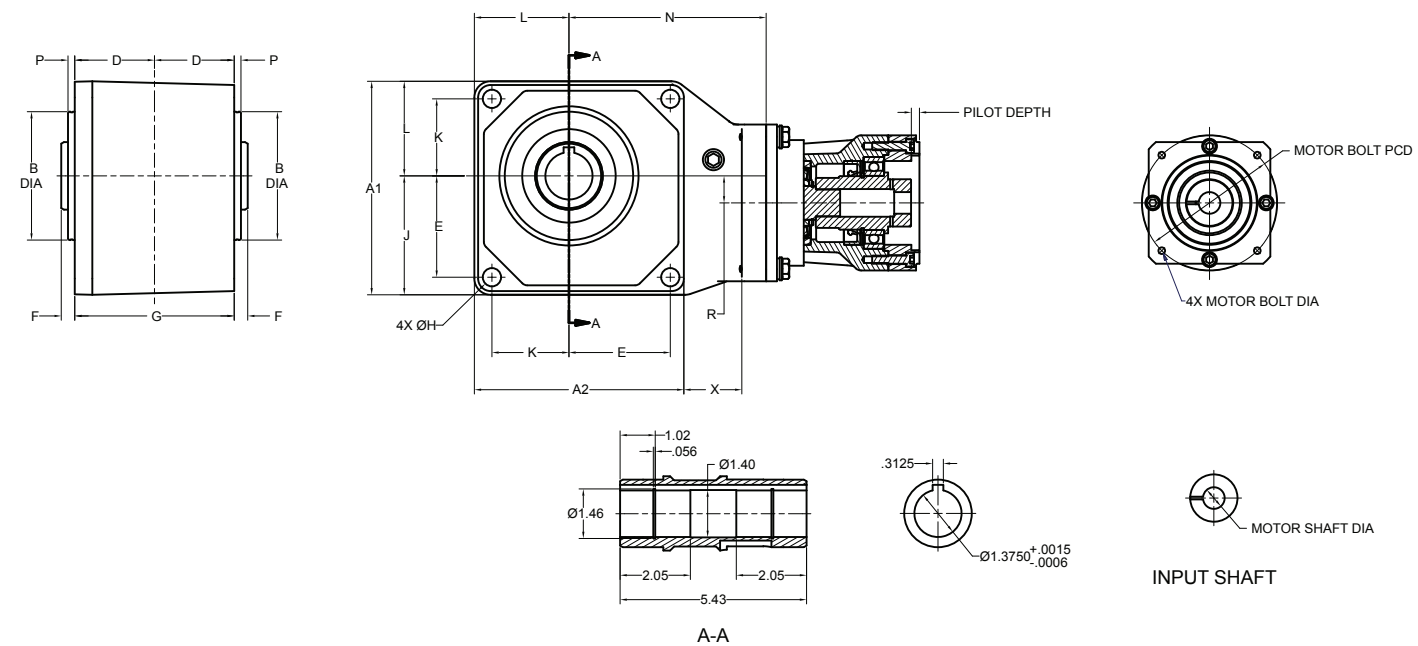
Model	Ratio	NEMA Frame	CE	C	AK	BD	AJ	BF	Z	BB	ZA	Wt. (lbs.)
<b>RNYX-1320Y</b>	5~60	56C	10.67 (271)	10.39 (264)	4.500 (114.3)	6.69 (170)	5.875 (149.2)	0.43 (11)	0.87 (22)	0.20 (5.1)	4.53 (115)	18 (8)
<b>RNYX-1320Y</b>	5~30	143TC	10.7 (271)	10.4 (264)								

Model	NEMA Frame	XU	XU Tolerance	XV
<b>RNYX-1320Y</b>	56C	0.625	+0.0015 / +0.0008	1.93
<b>RNYX-1320Y</b>	143TC	0.875	+0.0019 / +0.001	

Dimensions shown are for reference only and are subject to change without notice, unless certified. Certified prints are available after receipt of an order; consult factory.

# Dimensions

## Frame Size 1400 RNYX-1420



All dimensions are in inches (mm).

Per NEMA standard

Model	A1	A2	B min	B max	D	E	F	G	H	J	K	L	N	P	R	X
<b>1420Y</b>	6.22 (158)	6.10 (155)	3.7388 (94.965)	3.740 (95.000)	2.32 (59)	2.95 (75)	0.39 (10)	4.65 (118)	0.55 (14)	3.46 (88)	2.24 (57)	2.76 (70)	5.75 (146)	0.20 (5)	0.79 (20)	1.69 (43)

Model	Ratio	NEMA Frame	CE	C	AK	BD	AJ	BF	Z	BB	ZA	Wt. (lbs.)
<b>RNYX-1420Y</b>	5~60	56C~145TC	12.4 (316)	12.1 (308)	4.500 (114.3)	6.69 (170)	5.875 (149.2)	0.43 (11)	0.87 (22)	0.20 (5.1)	4.53 (115)	28 (13)

Model	NEMA Frame	XU	XU Tolerance	XV
<b>RNYX-1420Y</b>	56C	0.625	+0.0015 / +0.0008	2.01
<b>RNYX-1420Y</b>	143TC	0.875	+0.0019 / +0.001	2.05

Dimensions shown are for reference only and are subject to change without notice, unless certified. Certified prints are available after receipt of an order; consult factory.



---

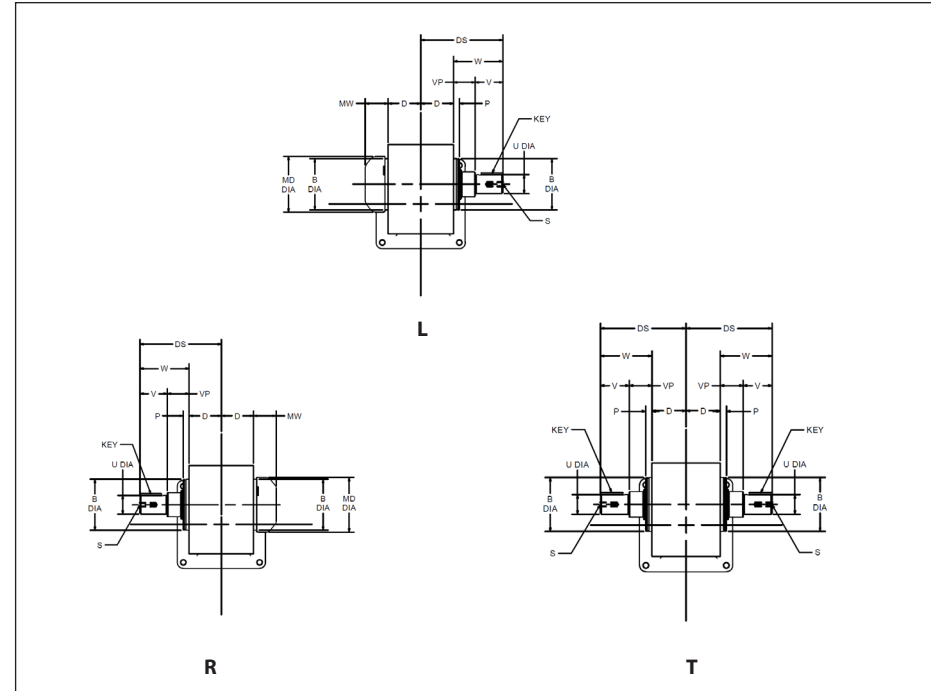
Page intentionally left blank.

# 3 Options

---

# Plug-in Solid Output Shaft

Frame Size 1100 ~ 1300



All dimensions are in inches.

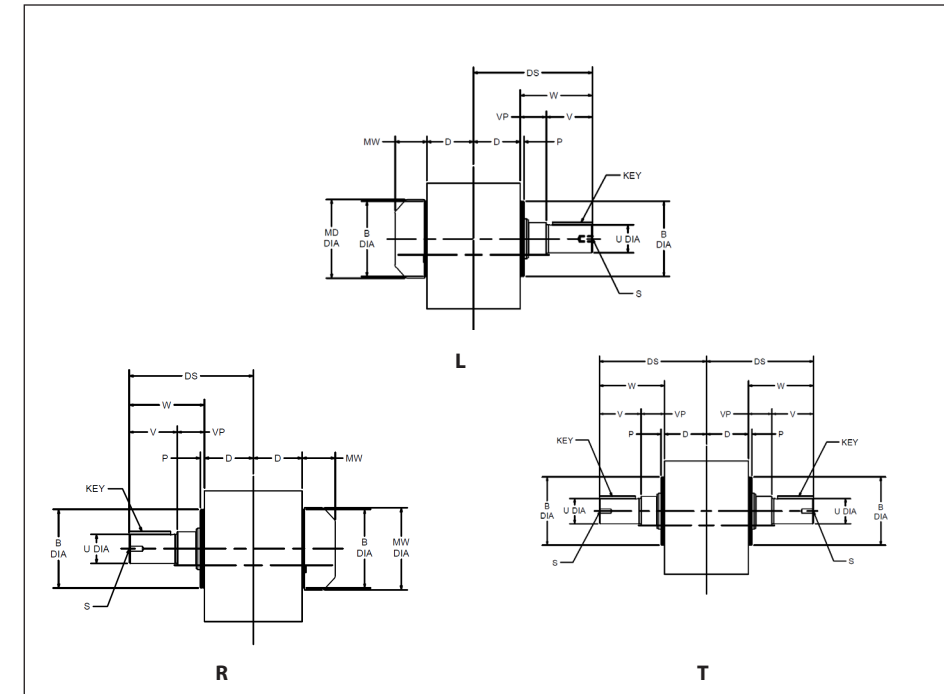
Model	B min	B max	D	DS	H	P	MD	MW
1120L/R/TY-X1	2.046	2.047	1.30	3.27	0.26	0.24	2.20	0.79
1220L/R/TY-X1	3.070	3.071	1.46	3.96	0.35	0.20	2.32	1.26
1320L/R/TY-X1	3.345	3.346	1.81	4.61	0.43		2.64	

Model	Output Shaft						
	U min	U max	W	V	VP	S	Key
1120L/R/TY-X1	0.749	0.750	1.97	1.10	0.87	10-32 UNF x 0.630	3/16 x 3/16
1220L/R/TY-X1	0.999	1.000	2.50	1.42	1.08	5/16-18 UNC x 0.630	1/4 x 1/4
1320L/R/TY-X1	1.249	1.250	2.80	1.65	1.14		

Dimensions shown are for reference only and are subject to change without notice, unless certified. Certified prints are available after receipt of an order; consult factory.

# Plug-in Solid Output Shaft

Frame Size 1400



All dimensions are in inches.

Model	B min	B max	D	DS	H	P	MD	MW
1420L/R/TY-X1	3.739	3.740	2.32	5.91	0.55	0.20	3.03	1.65

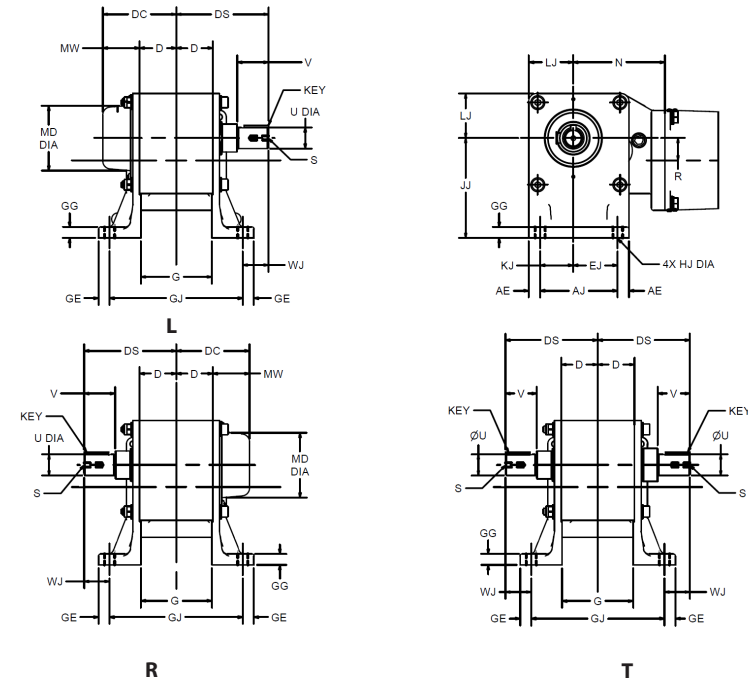
Model	Output Shaft						
	U min	U max	W	V	VP	S	Key
1420L/R/TY-X1	1.374	1.375	3.58	2.28	1.30	5/16-18 UNC x 0.630	5/16 x 5/16

Note: [1] For double extended output shaft, U min=1.499, U max = 1.500.

Dimensions shown are for reference only and are subject to change without notice, unless certified. Certified prints are available after receipt of an order; consult factory.

# Plug-in Shaft with Bolt-on Feet

Frame Size 1100 ~ 1400



All dimensions are in inches.

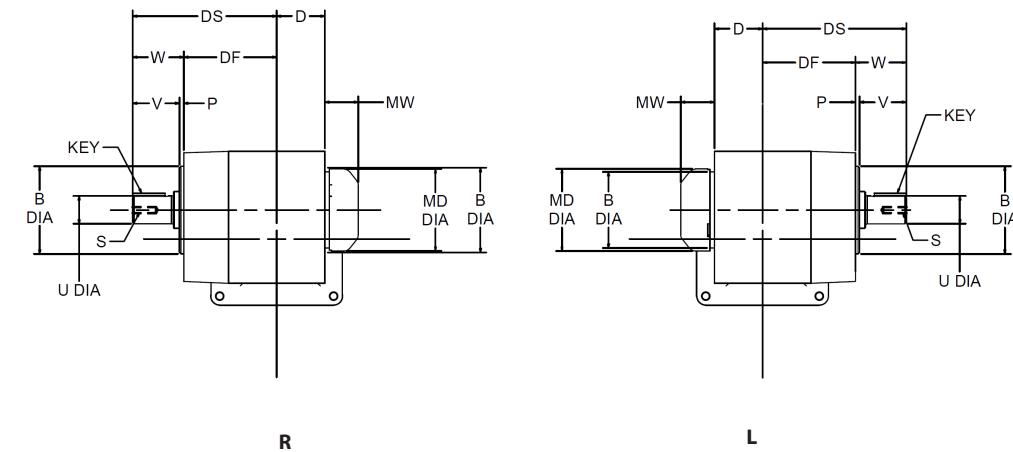
Model	AJ	AE	D	DS	DC	G	GJ	GE	JJ	LJ	GG	KJ	EJ	HJ	N	R	MD	MW
1120L/R/TY-J1	2.76	0.39	1.30	3.27	2.09	2.52	4.72	0.39	3.54	1.57	0.39	1.26	1.50	0.35	3.23	0.79	2.20	0.79
1220L/R/TY-J1	4.13	0.43	1.46	3.96	2.72	2.83	5.35	0.59	4.33	2.01	0.39	1.57	2.56	0.35	3.78	1.10	2.32	1.26
1320L/R/TY-J1	4.96	0.51	1.81	4.61	3.07	3.54	6.46		4.41	2.36	0.47	1.85	3.11	0.43	4.69	1.08	2.64	
1420L/R/TY-J1	5.51	0.75	2.32	5.91	3.98	4.57	8.03		5.20	2.76	0.47	2.01	3.50	0.55	5.75	0.79	3.03	

Model	Output Shaft					Key
	U min	U max	WJ	V	S	
1120L/R/TY-J1	0.749	0.750	0.91	1.10	10-32 UNF x 0.630	3/16 x 3/16
1220L/R/TY-J1	0.999	1.000	1.28	1.42	5/16-18 UNC x 0.630	1/4 x 1/4
1320L/R/TY-J1	1.249	1.250	1.38	1.65		
1420L/R/TY-J1	1.374	1.375	1.89	2.28		

Dimensions shown are for reference only and are subject to change without notice, unless certified. Certified prints are available after receipt of an order; consult factory.

# Extended Flange

Frame Size 1100 ~ 1400



All dimensions are in inches.

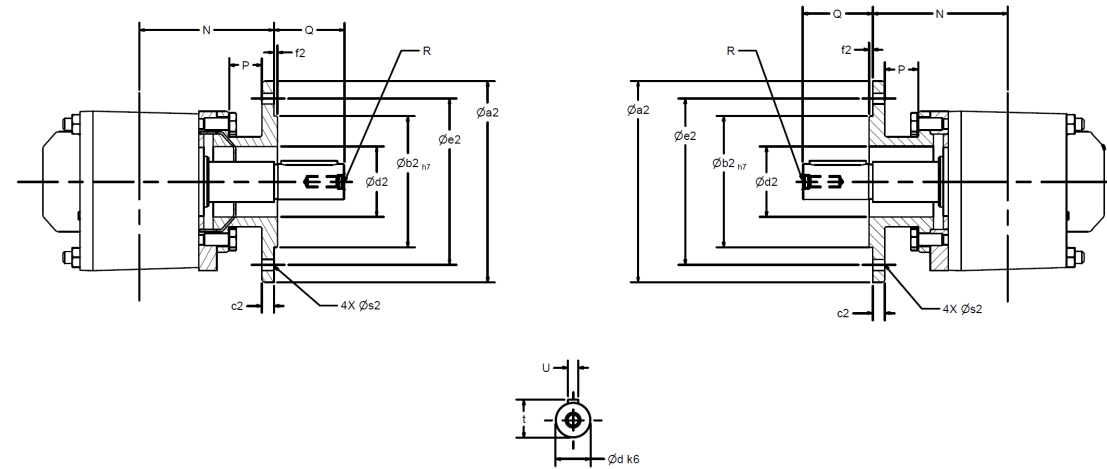
Model	B min	B max	H	D	DF	P	DS	MD	MW
1120L/R-P1/Q1	2.361	2.362	0.26	1.30	2.50	0.12	3.80	2.20	0.79
1220L/R-P1/Q1	3.345	3.346	0.35	1.46	3.25		4.86	2.32	1.26
1320L/R-P1/Q1	3.699	3.701	0.43	1.81	3.48		5.33	2.64	
1420L/R-P1/Q1	4.132	4.134	0.55	2.32	3.74		6.22	3.03	

Model	Output Shaft					Key H
	U min	U max	W	V	S	
1120L/R-P1/Q1	0.749	0.750	1.30	1.10	10-32 UNF x 0.630	3/16 x 3/16
1220L/R-P1/Q1	0.999	1.000	1.61	1.42	5/16-18 UNC x 0.630	1/4 x 1/4
1320L/R-P1/Q1	1.249	1.250	1.85	1.65		
1420L/R-P1/Q1	1.374	1.375	2.48	2.28		

Dimensions shown are for reference only and are subject to change without notice, unless certified. Certified prints are available after receipt of an order; consult factory.

# Metric Flange

Frame Size 1120 ~ 1420

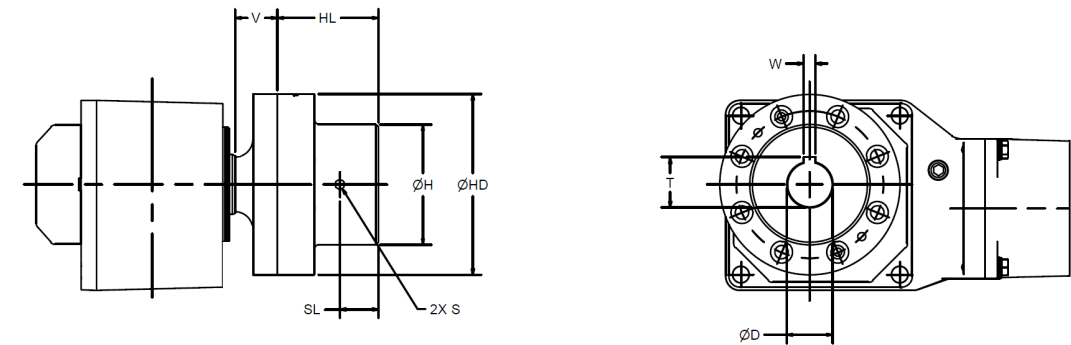


All dimensions are in mm.

Frame	HP	a2	b2	c2	d2	e2	f2	s2	N	d k6	P	Q	R	t	u
1120	1/8 1/4	120	80	8	38	100	3	6.6	81	20	22	40	M6x15	22.5	6
1220	1/8 1/4 1/3 1/2	120	80	8	55	100	3	6.6	87	25	22	50	M10x22	28	8
1320	1/4 1/3 1/2 3/4 1	160	110	10	60	130	3.5	9	111	30	30	60	M210x22	33	8
1420	1/2 3/4 1 1.5 2	200	130	12	70	165	3.5	11	134	35	33	70	M12x28	38	10

# Flange Shaft

Frame Size 1420



All dimensions are in inches.

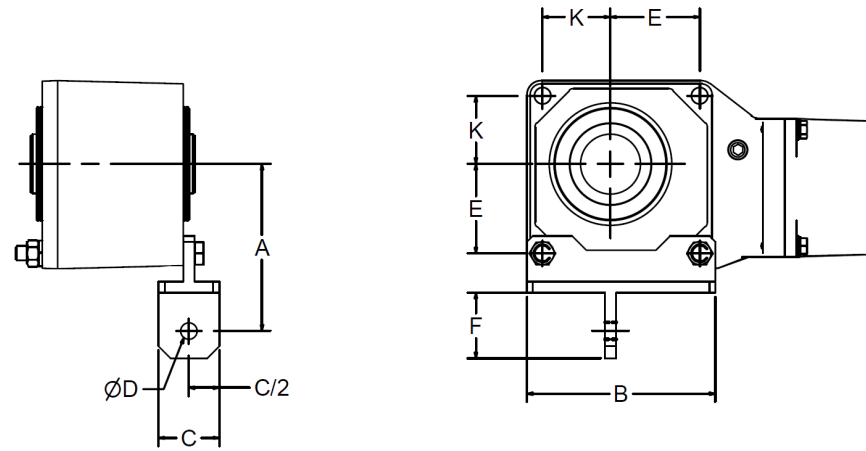
Frame	H	HD	HL	SL	V
1420Y	3.94	5.91	3.31	1.26	1.38

Shaft Diameter	D	S	T	W
1-3/8	1.375 0.0015 -0	1/4"-20UNC	1.518 +0.010 -0.000	0.3125 +0.002 -0.000
1-7/16	1.4375 0.0015 -0	5/16"-18UNC	1.605 +0.010 -0.000	0.3750 +0.002 -0.000
1-11/16	1.6875 0.0015 -0	5/16"-18UNC	1.859 +0.010 -0.000	0.3750 +0.002 -0.000
1-15/16	1.9375 0.0015 -0	3/8"-16UNC	2.160 +0.010 -0.000	0.5000 +0.002 -0.000

Dimensions shown are for reference only and are subject to change without notice, unless certified. Certified prints are available after receipt of an order; consult factory.

# T-Type Torque Arm

## Frame Size 1420



All dimensions are in inches.

Frame	A	B	C	ØD	E	F	K
1420Y	5.51	6.22	2.00	0.55	2.95	2.17	2.24

# Shaft Dimensions

Symbols: ● Standard ○ Optional ◆ Standard Stainless Steel (AISI 304)  
Consult factory for price and delivery.

**Table 3.1 Hollow Shaft Dimensions (in.)**

Bore Size (in.)	Frame Size			
	1120	1220	1320	1420
3/4	●	○	○	
13/16		○	○	
7/8		○	○	
15/16		○	○	
1		● ◆	○	○
1-1/8			○ ◆	○
1-3/16			○ ◆	○
1-1/4			● ◆	○ ◆
1-5/16				○
1-3/8				● ◆
1-7/16				○ <sup>[1]</sup> ◆

**Table 3.2 Solid Shaft Dimensions (in.)**

Bore Size (in.)	Frame Size			
	1120	1220	1320	1420
3/4	●			
1		●		
1-1/4			●	
1-5/16				
1-3/8				●

Notes: [1] Special maximum bore size for frame size 1420 is 1-7/16".  
[2] Standard shaft dimension for double extended type shaft.  
[3] Plug-in shaft only, not available with foot.



# Shrink Disc

A shrink disc provides a reliable, keyless, high-strength connection to the driven shaft with zero backlash. It is ideal for applications that typically require an interference between the shaft and hollow bore. Sumitomo strongly recommends a shrink disc for applications involving frequent starts per hour.

When ordering, use the Special Specification Code (SSC) R61 for right side (when viewed from the motor end), or R62 for left side (when viewed from the motor end).

The user shaft should conform to JIS h6 tolerances. Shafts outside that range may not develop sufficient clamping force. The shaft surface finish should be between 63 to 125 micro-inches RMS.

Shrink Disc Availability:

Not available for 5:1 ratio, frame sizes 1120~1420.

**Table 3.3 Shrink Disc Availability** Symbols: ● Standard ○ Option ◆ Standard Stainless Steel (AIS 304)

Bore Size (in.)	Driven Shaft Tolerance (JIS h6)	Frame Size*			
		1120	1220	1320	1420
3/4	+0.0000 -0.0051	●	○		
13/16	+0.0000 -0.0051		○		
7/8	+0.0000 -0.0051		○	○	
15/16	+0.0000 -0.0051		○	○	
1	+0.0000 -0.0051		● ◆	○	
1-1/8	+0.0000 -0.0051			○ ◆	○
1-3/16	+0.0000 -0.0063			○ ◆	○
1-1/4	+0.0000 -0.0063			● ◆	○ ◆
1-5/16	+0.0000 -0.0063				○
1-3/8	+0.0000 -0.0063				● ◆
1-7/16	+0.0000 -0.0063				○ ◆

# Industry Packages

Four food-grade packages are available for use in machinery where there is incidental food contact. (Chemi SHIELD, SHIELD360, Food-Grade, and Ultra SHIELD360)

Modification	Chemical Duty	Chemi SHIELD 360*	Low Temp	Washdown IP55	Food-Grade	SHIELD 360*	Ultra SHIELD 360*
DuPont Alesta® AM Powder Coat	✓			✓	✓		
FDA White Epoxy Top Coat						✓	
FDA Silver Grey Epoxy Top Coat		✓					✓
FDA Grease					✓	✓	✓
Low Temp Grease			✓				
Silicone Seals			✓				
FKM Antimicrobial Seals	✓	✓					✓
Stainless or Tesa Nameplate	✓	✓					✓
Stainless Output Shaft		✓					✓

Stainless Steel Solid Shaft - maximum torque ratings with standard solid shaft diameters are the same as those listed in this catalog for standard models. Consult the factory when ordering smaller than standard diameters, or if there will be overhung load.

\* UltraShield360™ available in quill input option only

Low Temp Package = -30 degrees C Maximum. For lower temperature requirements consult factory.

High Temp Package = 50 degrees C Maximum. For higher temperature requirements consult factory.



---

Page intentionally left blank.



# 4

# Technical Information

---

# Exact Ratios

The exact reduction ratios for the Hyponic can be calculated given the number of gear teeth in a reduction stage.

Per reduction stage, the reduction ratio is determined by dividing the number of teeth in the gear by the number of teeth in the pinion. The overall gearbox reduction ratio is the product of the individual stage reduction ratios.

$$\text{Overall Reduction Ratio} = i_{\text{OVERALL}} = (1\text{ST}_{\text{GEAR}} / 1\text{ST}_{\text{PINION}}) (2\text{ST}_{\text{GEAR}} / 2\text{ST}_{\text{PINION}}) (3\text{ST}_{\text{GEAR}} / 3\text{ST}_{\text{PINION}}) (4\text{ST}_{\text{GEAR}} / 4\text{ST}_{\text{PINION}})$$

- where:
- 1ST<sub>GEAR</sub> / 1ST<sub>PINION</sub> = Tooth count of first stage pinion and gear respectively
  - 2ST<sub>GEAR</sub> / 2ST<sub>PINION</sub> = Tooth count of second stage pinion and gear respectively
  - 3ST<sub>GEAR</sub> / 3ST<sub>PINION</sub> = Tooth count of third stage pinion and gear respectively (if applicable)
  - 4ST<sub>GEAR</sub> / 4ST<sub>PINION</sub> = Tooth count of fourth stage pinion and gear respectively (if applicable)

**Table 3.4: Tooth Counts and Calculated Reduction Ratios for Nominal Ratios 5-240:1**

Normal Ratio	Frame Size	Number of Teeth				Calculated Ratio
		1ST <sub>PINION</sub>	1ST <sub>GEAR</sub>	2ST <sub>PINION</sub>	2ST <sub>GEAR</sub>	
5	1120	9	45	38	38	5.0000
	1320	9	45	37	37	5.0000
	1420	9	45	39	39	5.0000
7	1120	9	45	32	45	7.0313
	1320	9	45	32	45	7.0313
	1420	9	45	33	46	6.9697
10	1120	9	45	26	51	9.8077
	1320	9	45	26	51	9.8077
	1420	9	45	26	52	10.0000
12	1120	9	45	23	54	11.7391
	1320	9	45	23	54	11.7391
	1420	9	45	23	55	11.9565
15	1120	9	45	19	58	15.2632
	1320	9	45	19	58	15.2632
	1420	9	45	20	59	14.7500

**Table 3.4: Tooth Counts and Calculated Reduction Ratios for Nominal Ratios 5-240:1 (cont.)**

Normal Ratio	Frame Size	Number of Teeth						Calculated Ratio
		1ST <sub>PINION</sub>	1ST <sub>GEAR</sub>	2ST <sub>PINION</sub>	2ST <sub>GEAR</sub>	3ST <sub>PINION</sub>	3ST <sub>GEAR</sub>	
20	1120	9	45	15	62	—	—	20.6667
	1320	9	45	15	62	—	—	20.6667
	1420	9	45	16	63	—	—	19.6875
25	1120	9	45	13	64	—	—	24.6154
	1320	9	45	13	64	—	—	24.6154
	1420	9	45	13	65	—	—	25.0000
30	1120	9	45	11	66	—	—	30.0000
	1320	9	45	11	66	—	—	30.0000
	1420	9	45	11	67	—	—	30.4545
40	1120	6	60	15	62	—	—	41.3333
	1320	6	60	15	62	—	—	41.3333
	1420	6	60	16	63	—	—	39.3750
50	1120	6	60	13	64	—	—	49.2308
	1320	6	60	13	64	—	—	49.2308
	1420	6	60	13	65	—	—	50.0000
60	1120	6	60	11	66	—	—	60.0000
	1320	6	60	11	66	—	—	60.0000
	1420	6	60	11	67	—	—	60.9091



# Shaft Rotation

Figure 3.1 Rotation Ratios

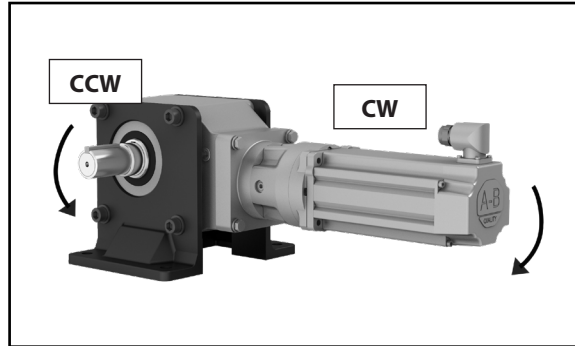


Table 3.5 Shaft Rotation Direction

Model	Counter Clockwise Reduction Ratio (:1)
1120	5, 7, 10, 12, 15, 20, 25, 30, 40, 50, 60
1220	5, 7, 10, 12, 15, 20, 25, 30, 40, 50, 60
1320	5, 7, 10, 12, 15, 20, 25, 30, 40, 50, 60
1420	5, 7, 10, 12, 15, 20, 25, 30, 40, 50, 60

# Special Load Guidelines Overhung Load

## Reducer/Gearmotor Allowable Overhung Load

When a sprocket, sheave, or gear is mounted on the shaft of a reducer, an overhung load is applied on that shaft. It is necessary to check if the shaft of the Hyponic® Speed Reducer will allow the overhung load. Calculate the overhung load using this formula:

$$Pr = \frac{TI}{R} \leq \frac{Pro}{Lf \cdot Cf \cdot Fs} \quad (\text{lbs, N})$$

LEGEND

- Pr: Actual radial load (lbs, N)
- TI: Actual transmitted torque on slow speed shaft of reducer (lb-in, N-m)
- R: Pitch circle radius of sprocket, gear, pulley, ect. (inch, meter)
- Pro: Allowable radial load (lbs, N)
- Cf: Coupling factor
- Fs: Shock factor
- Lf: Load Location factor = 1.0

Table 3.6 Load Connection Factor

Type of Connection		Cf
General Purpose Chain	Single Row	1.00
	Double Row	1.25
Machined Gear or Pinion		1.25
Synchronous Belt		1.50
V-Belt		1.50
Flat Belt		2.50

Table 3.7 Shock Factor

Shock Factor	Fs
No Shock	1.0
Moderate Shock	1.3
Heavy Shock	1.6

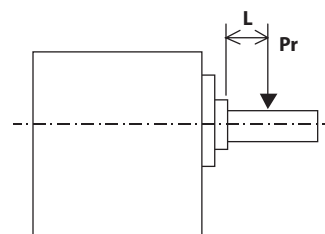


Figure 3.2

# Special Load Guidelines Inertia

Table 3.8 Reducer Moment of Inertia, Ratios 5 ~ 60

Units: lb-inch<sup>2</sup> (x 10<sup>-4</sup> kg-m<sup>2</sup>)

Model	Reduction Ratio										
	5	7	10	12	15	20	25	30	40	50	60
1120	0.149	0.145	0.143	0.143	0.142	0.142	0.141	0.141	0.134	0.134	0.134
1220	0.216	0.200	0.194	0.192	0.190	0.189	0.188	0.188	0.168	0.168	0.168
1320	0.351	0.336	0.323	0.317	0.310	0.304	0.302	0.300	0.238	0.238	0.237
1420	0.647	0.607	0.566	0.553	0.540	0.525	0.515	0.510	0.367	0.364	0.363

# Construction

Figure 3.3 Hollow Shaft Type Example (RNYM1-1420-EP-120)

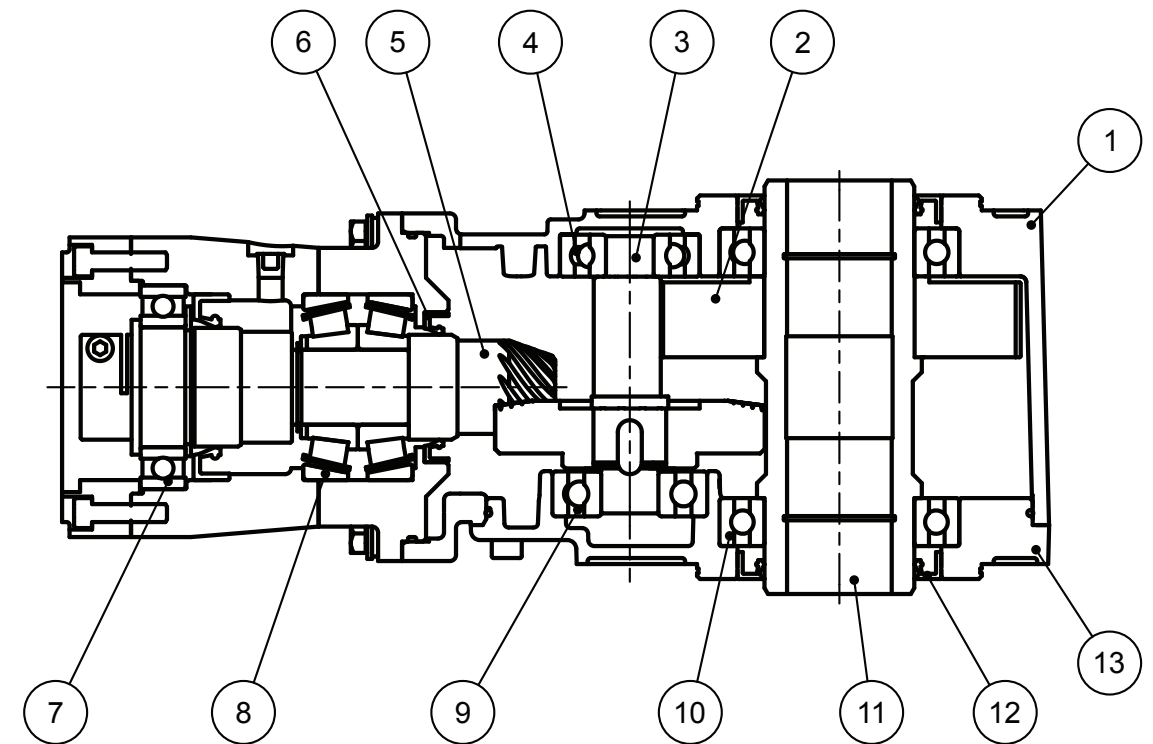


Table 3.9 Hollow Shaft Type Parts

Part No.	Description	Part No.	Description	Part No.	Description	Part No.	Description
1	Casing (1)	4	Pinion shaft bearing	7	Hypoid pinion shaft bearing (1)	10	Output shaft bearings
2	Gear	5	Hypoid pinion shaft	8	Hypoid pinion shaft bearing (2)	11	Output shaft
3	Pinion shaft	6	Hypoid pinion shaft seals	9	Pinion shaft bearing (2)	12	Output shaft seals
						13	Casing (2)

# Mounting

## Recommended Shaft Tolerances for Hollow Bore Hyponic®

According to JIS standard and based on loading conditions, recommended shaft tolerances for hollow bore Hyponic® are:

- Steady, uniform loads: **JIS h6/js6 (low shock load)**
- Shock load or large overung load: **JIS js6/k6 (high shock load)**
- Snap ring size is in accordance with: **JIS B2804C**

Refer to tables 5.15 and 5.16 for corresponding shaft diameters.

**Table 3.10 Metric Bore Output Shaft Diameters (mm)**

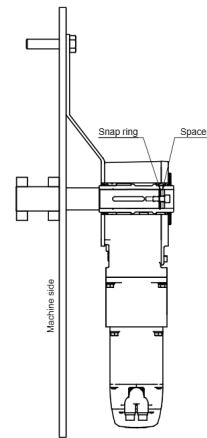
Bore Size	Low Shock Load JIS h6/js6		High Shock Load JIS js6/k6	
	Min	Max	Min	Max
20	19.9870	20.0065	19.9935	20.0150
25	24.9870	25.0065	24.9935	25.0150
30	29.9870	30.0065	29.9935	30.0150
35	34.9840	35.0080	34.9920	35.0180

**Table 3.11 Inch Bore Output Shaft Diameters (in.)**

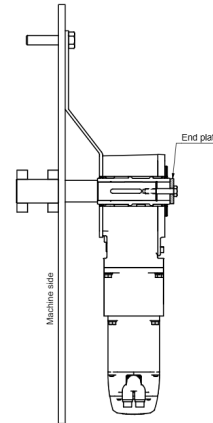
Bore Size	Low Shock Load JIS h6/js6		High Shock Load JIS js6/k6	
	Min	Max	Min	Max
3/4	0.74950	0.75025	0.74975	0.75060
13/16	0.81200	0.81275	0.81225	0.81310
7/8	0.87450	0.87525	0.87475	0.87560
15/16	0.93700	0.93775	0.93725	0.93810
1	0.99950	1.00025	0.99975	1.00060
1-1/8	1.12450	1.12525	1.12475	1.12560
1-3/16	1.18700	1.18775	1.18725	1.18810
1-1/4	1.24940	1.25030	1.24970	1.25070
1-5/16	1.31190	1.31280	1.31220	1.31320
1-3/8	1.37440	1.37530	1.37470	1.37570
1-7/16	1.43690	1.43780	1.43720	1.43820

## 4. Securing the Hyponic® Drive to Prevent Movement Away from the Machine Side (Figures 3.4 – 3.6)

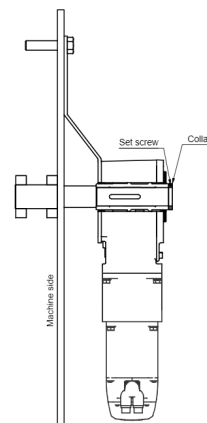
**Figure 3.4 Secured by Spacer and Snap Ring**



**Figure 3.5 Secured by End Plate**



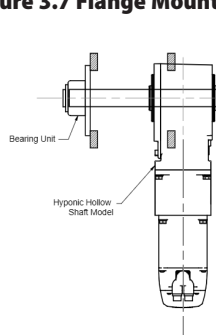
**Figure 3.6 Secured by Set Screw and Collar**



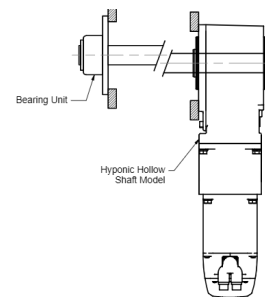
## 5. Flange Mounting and Casing Bottom Mounting (optional)

Handle with care. Do not apply excessive force to the driven shaft or hollow shaft by twisting the Hyponic® casing. Excessive force on the Hyponic® and bearing unit may damage internal parts.

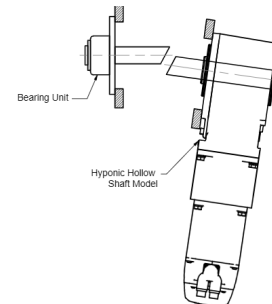
**Figure 3.7 Flange Mounting Surface**



**Correct**



**Incorrect:** Poor concentricity of driven shaft and mounting flange



**Incorrect:** Poor perpendicularity of driven shaft center and mounting flange surface

# Accessories Output Shaft Safety Cover, Torque Arm

## Output Shaft Safety Cover

Included with all hollow bore models.

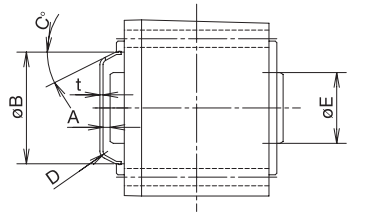
**Table 3.11 Output Shaft Safety Cover Dimensions for keyed hollow bore.**

Symbols: M: Screw size P: Thread pitch L: Thread length P.C.D: Mounting pitch N: Quantity

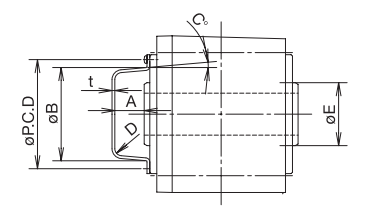
Model	Safety Cover								Output Shaft End	Fig. #
	A	øB	C°	D	t	øP.C.D	N	MxPxL (mm)		
1100	0.39	2.20	45	R0.12	0.08	(screw not required for this model)		1.18	5.14	
1200	0.83	2.32	5	R0.20	0.08	2.76	2	M3x0.5x6	1.57	5.15
1300	0.83	2.64	5	R0.20	0.08	3.07	2	M3x0.5x6	1.77	5.15
1400	1.18	3.03	5	R0.20	0.08	3.46	2	M3x0.5x6	2.17	5.15

Note: Safety cover dimensions may differ for other style hollow shafts.

**Figure 3.8 Frame Size 1100**

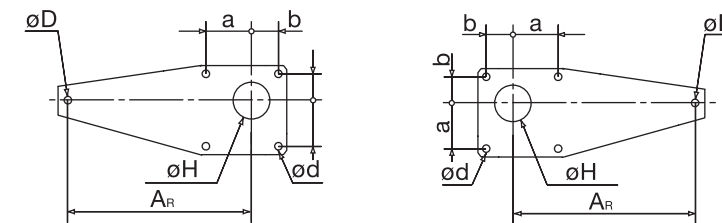


**Figure 3.9 Frame Sizes 1200 ~1400**



## Torque Arm

**Figure 3.10 Recommended Dimensions for customer designed torque arms**



**Table 3.12 Hyponic® Torque Arm Recommended Dimensions (in.)<sup>[1]</sup>**

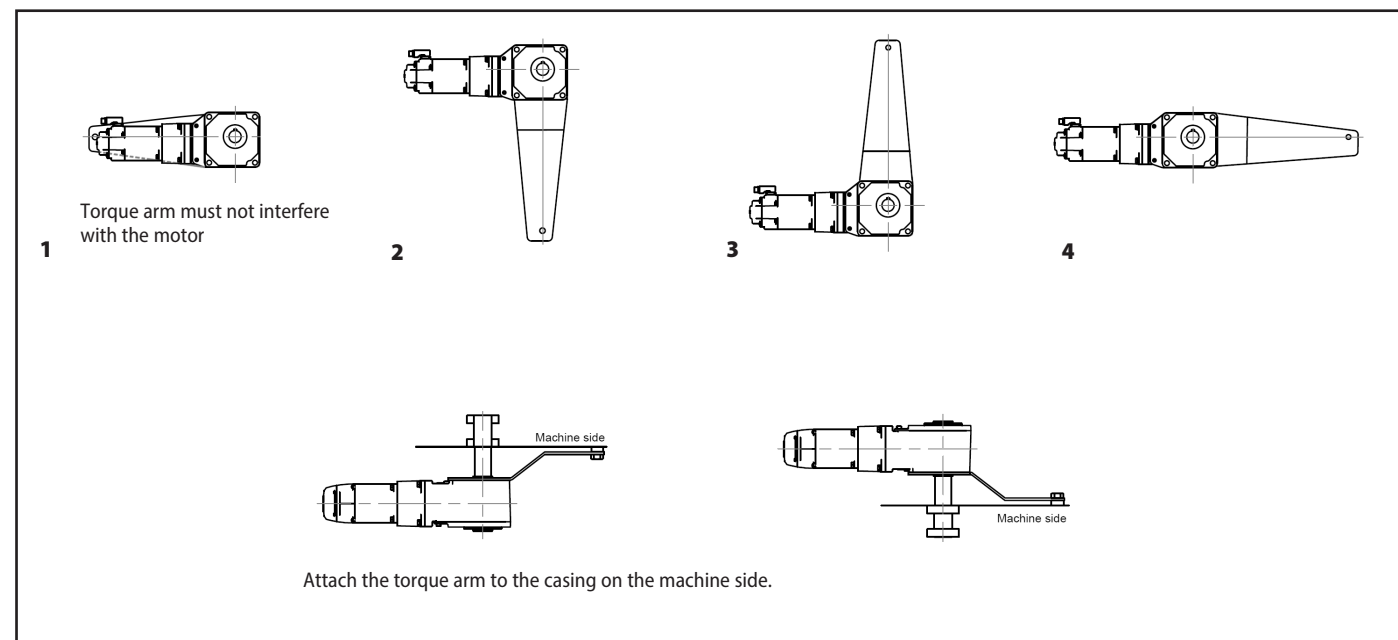
Model	Length A <sub>R</sub>	Bore øH	Stop Hole øD	Mounting Pitch		Mounting Hole ød	Thickness
				a	b		
1120	3.15	2.13	0.35	1.65	1.26	0.28	0.13
1220	3.94	3.15	0.43	2.24	1.57	0.35	0.18
1320	4.72	3.43	0.55	2.44	1.81	0.43	0.18
1420	5.51	3.82	0.71	2.95	2.24	0.55	0.24

Note 1: These dimensions do not correspond to Sumitomo designed torque arms

# Accessories Torque Arm continued

# Lubrication

Figure 3.13 Hyponic® Torque Arm Mounting Examples



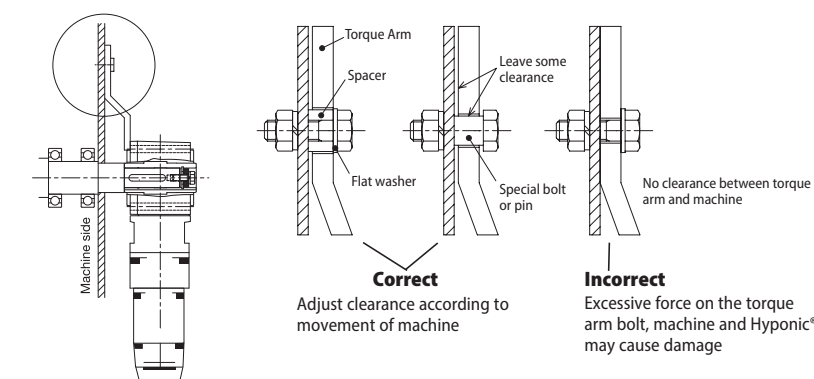
**Torque Arm Mounting:**

1. Attach the torque arm to the Hyponic® casing on the machine side using hex socket head cap screws. Refer to Table 3.13 for bolt sizes.
2. Leave some clearance between the torque arm and machine, and the torque arm and mounting bolt, so excessive force will not be applied to the Hyponic® and driven shaft.
3. For frequent start/stop applications, or repeated normal/reverse operations, use a rubber bushing between the torque arm and mounting bolt (or spacer) to absorb the shock.

Table 3.13 Torque Arm Bolt Sizes

Model	Bolt
1120,	M8
1220, 1340	M10
1320, 1440	M12
1420	M16

Figure 3.14 Hyponic® Torque Arm Clearance



Hyponic® drives are filled with long-life grease and sealed, so replenishment is unnecessary, but overhaul in approximately 20,000 hours or three to five years of operation will provide longer service life. Operating conditions affect oil seal durability. Under severe conditions, they may require changing in less than 20,000 hours or three years of operation. Gearmotors must be overhauled at factory-authorized locations.

Table 3.14 Hyponic Greases

Grease	Description	Temperature Range
<b>Nihon Koyu BA-11A</b>	Standard Grease	14°F to 104°F (-10°C to 40°C)
<b>Nihon Koyu BH-17B</b>	Low Temperature Grease	-22°F to 14°F (-30°C to -10°C)
<b>Cassida-SGG 000</b>	Food Grade Grease	14°F to 104°F (-10°C to 40°C)

# Paint and Rust-proofing Specifications

Table 3.15 Paint Specifications

Paint Classification	Coating Name	Paint Color	Resin Type	Dry Time (hrs.)
<b>Food and Beverage Industry Antimicrobial Powder Coating (standard)</b>	Dupont Alesta	Silver Freeze	TGIC-Polyester	-
<b>SMA Blue Paint (optional)</b>	DTM Water-Based Enamel	Blue	Water-Based Acrylic Polymer Polyimide	1 – 1½
<b>Epoxy (optional)</b>	Heavy-Duty Epoxy	Blue	Converted Epoxy	4 – 6
<b>FDA-USDA (optional)</b>	Food and Beverage Industry Coating	High Gloss White or Silver	Modified Alkyd	4 – 7

- All completely assembled models receive rust-proofing treatment prior to shipment.
- All models for export receive rust-proofing treatment that is effective for 12 months. Please specify "export Rust-proofing" for all export models.
- Please consult factory for storage longer than those listed in Table 3.16 or in the event of adverse storage conditions.

Table 3.16 Rust-proofing Specifications

<b>Rust-Proofing Period</b>	1 Year
<b>Storage Condition</b>	Indoor environment that is relatively free of humidity, dust, extreme temperature fluctuation, corrosive gas, etc.

# Warranty

Company warrants that (i) all new equipment and parts (collectively, "Equipment") sold by Company will conform to printed drawings and specification sheets issued by Company and (ii) are free of defects in material and workmanship for the time period shown in Table 3.17. The warranty period commences on the date of shipment of the Equipment by Company.

If, within the warranty period, Company receives from Buyer written notice of any alleged defect in any of the Equipment and, if the Equipment is found by Company not to conform with these warranties (after Buyer has provided Company a reasonable opportunity to perform any appropriate tests on the allegedly defective Equipment), Company will, at its sole option and expense, either repair or replace the Equipment. In all instances, Company reserves the right to require Buyer to deliver the Equipment for repair or replacement to a designated service center and require Buyer to pay all charges for inbound and outbound transportation and for services of any kind, diagnostic or otherwise, excepting only the direct and actual cost of Equipment repair or replacement. Warranty coverage is limited to parts and labor and does not include travel and other expenses. Buyer applications and use of the Equipment may require installation of safety features. Buyer is responsible for furnishing and installing guards or other safety equipment needed to protect operating personnel, even though such equipment may not be furnished by Company with the Equipment purchased. Equipment supplied, but not manufactured, by Company is warranted only to the extent of the original manufacturer's warranty.

**Table 3.17 - Product Warranty**

Product	Warranty Period (After Shipment)	Components Excluded
Cyclo® Speed Reducers and Gearmotors	2 Years	Normally Wearing Items
Cyclo® Bevel Buddybox Speed Reducers and Gearmotors	2 Years	Normally Wearing Items
Cyclo® Helical Buddybox Speed Reducers and Gearmotors	2 Years	Normally Wearing Items
Fine Cyclo® Speed Reducers	2 Years	Normally Wearing Items
Beier® Variator Mechanical Adjustable Speed Reducers	2 Years	Normally Wearing Items
Hyponic® Speed Reducers and Gearmotors	2 Years	Normally Wearing Items
Hedcon® Double Enveloping Worm Gear Speed Reducers	2 Years	Normally Wearing Items
Helical Shaft Mount Speed Reducers	2 Years	Normally Wearing Items
Rhytax®	2 Years	Normally Wearing Items
IB Series Servo Gearheads	1 Year	Normally Wearing Items
Astero Gearmotors	1 Year	Normally Wearing Items
Variable Frequency Inverters	1 Year	---
Paramax® Speed Reducers	2 Years	Normally Wearing Items
Compower Planetary Speed Reducers	1 Year	Normally Wearing Items
Hansen UniMiner	2 Years	Normally Wearing Items
Hansen P4	2 Years	Normally Wearing Items
Parts	1 Year	---
Repairs	1 Year	Normally Wearing Items

# Motor Codes

Motor Code	Shaft Diameter	Shaft Length	Pilot Diameter	P. C. D	Hole Diameter	Square Flange
A0S	7	24	34	48	4 x ø 3.5	42
B0S	8	33	25.4	66.67	4 x ø 5	57
B14G	8	25	30	46	4 x ø 4.5	40
C25L	9	25	50	70	4 x ø 5.5	60
C6G	9	20	40	63	4 x ø 4.5	55
C8G	9	20	40	63	4 x ø 5.8	55
D30L	10	32	80	100	4 x ø 6.6	90
E11G	11	23	60	75	4 x ø 5.8	67
E11L	11	24	60	75	4 x ø 5.8	67
F25G	12	30	50	70	4 x ø 5.5	60
H0G	14	30	50	70	4 x ø 6.6	60
H10G	14	30	50	70	4 x ø 4.5	60
H11G	14	30	60	75	4 x ø 5.8	70
H12G	14	30	60	75	4 x ø 6.5	72
H12L	14	36.5	60	75	4 x ø 6.5	72
H18G	14	30	70	90	4 x ø 6.5	80
H20G	14	30	50	95	4 x ø 6.6	82
H25G	14	30	50	70	4 x ø 5.5	60
H25L	14	31	50	70	4 x ø 5.5	60
H30G	14	30	80	100	4 x ø 7	90
H35L	14	36	95	115	4 x ø 9	105
H48G	14	30	50	100	4 x ø 6.6	88
H60L	14	42	110	145	4 x ø 9	130
J0L	16	35	80.4	100	4 x ø 6.5	86
J18L	16	35	70	90	4 x ø 6.6	80
J30L	16	40	80	100	4 x ø 7	89.4
J30S	16	40.1	80	100	4 x ø 7	88.8
J60L	16	40	110	145	4 x ø 10	120
J60S	16	58	110	145	4 x ø 9	130
K60L	17	47	110	145	4 x ø 9	130
M17G	19	35	70	90	4 x ø 5.5	80
M18G	19	40	70	90	4 x ø 6.5	80
M30G	19	40	80	100	4 x ø 7	89
M30L	19	47	80	100	4 x ø 7	114
M35G	19	40	95	115	4 x ø 10	118
M35L	19	55	95	115	4 x ø 9	100
M45G	19	40	95	130	4 x ø 9	116
M50L	19	50	110	130	4 x ø 9.2	114.3

# Motor Codes

Motor Code	Shaft Diameter	Shaft Length	Pilot Diameter	P. C. D	Hole Diameter	Square Flange
M51L	19	50	110	130	4 x ø 11.5	115
M60G	19	40	110	145	4 x ø 9	120
M60L	19	58	110	145	4 x ø 9	130
M70G	19	40	130	165	4 x ø 12	142
M70L	19	46	130	165	4 x ø 11	142
N35G	22	40	95	115	4 x ø 9	100
N60G	22	45	110	145	4 x ø 9	130
N60L	22	58	110	145	4 x ø 9	130.4
N60S	22	70	110	145	4 x ø 9	130
Q0L	28	63	10	145	4 x ø 9	130
Q60G	28	58	110	145	4 x ø 9	130.4
Q60L	28	63	110	145	4 x ø 9	130
Q70G	28	60	130	165	4 x ø 12	146
Q70L	28	65	130	165	4 x ø 11	150
Q71G	28	60	130	165	4 x ø 10	143.5
Q76L	28	63	114.3	200	4 x ø 13.5	180
S70G	32	50	130	165	4 x ø 11	142
S70L	32	80	130	165	4 x ø 12	168.9
S71G	32	58	130	165	4 x ø 10.2	142
S80G	32	58	180	215	4 x ø 13	190
S88G	32	60	130	215	4 x ø 14	192
T76L	35	74	114.3	200	4 x ø 13.5	180
U70G	38	50	130	165	4 x ø 11.2	140.5
U80G	38	80	180	215	4 x ø 14.5	210.9
U80L	38	80.1	180	215	4 x ø 14.5	184.9
V76L	42	108	114.3	200	4 x ø 13.5	180
V80L	42	85	180	215	4 x ø 14.5	200
V87L	42	110	230	265	4 x ø 14.5	235
V90L	42	110	250	300	4 x ø 18	262
W0G	48	110	250	300	4 x ø 14.5	266.7
W80G	48	58	180	215	4 x ø 14	190
W90G	48	110	250	300	4 x ø 18.5	275.9
X83LS	55	116	200	235	4 x ø 13.5	220
X87L	55	110	230	265	4 x ø 14.5	250
X90S	55	132	250	300	4 x ø 18	265
X92L	55	110	300	350	4 x ø 18.5	400
Y24S	12.7	30.2	73.025	98.4	4 x ø 5.6	82.6
Y87S	60	140	230	265	4 x ø 13.5	250

# Motor Codes

Motor Code	Shaft Diameter	Shaft Length	Pilot Diameter	P. C. D	Hole Diameter	Square Flange
Y90S	65	150	250	300	4 x ø 18	265
Y92S	60	140	300	350	4 x ø 18	324
Z35G	24	50	95	115	4 x ø 9	104
Z36G	24	45	95	115	4 x ø 7	100
Z45G	24	50	95	130	4 x ø 9	116
Z50G	24	50	110	130	4 x ø 10	120
Z50L	24	50.6	110	130	4 x ø 10	113
Z60L	24	55	110	145	4 x ø 9	130
Z64G	24	50	110	165	4 x ø 11	140
Z70G	24	50	130	165	4 x ø 12	148
Z70L	24	58	130	165	4 x ø 12.5	142